

# ASSEMBLY INSTRUCTIONS

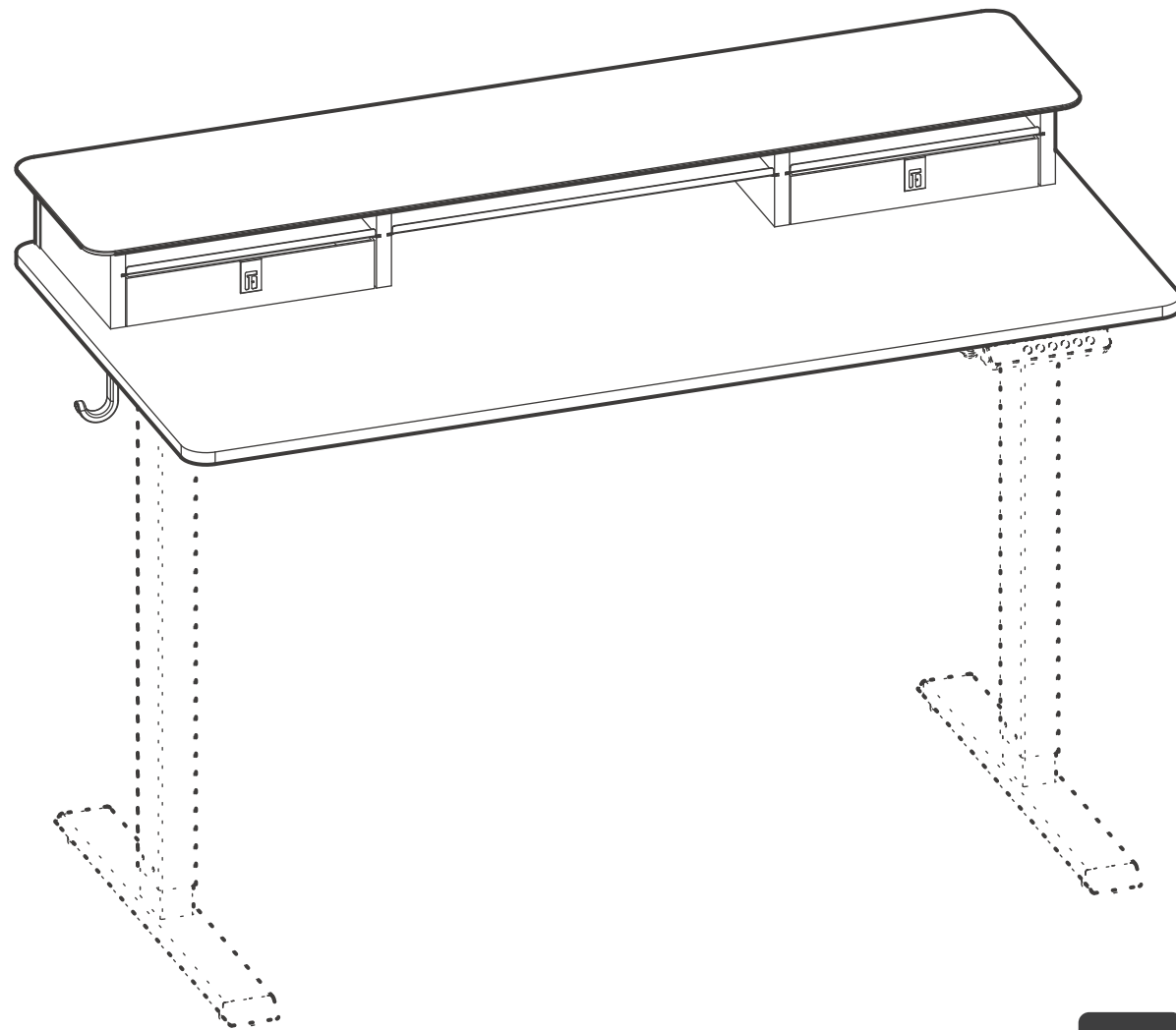

V1

**FEZiBO**  
Live more, stress less.



Hours: 24/5 Mon-Fri (DE) +44 7481 346904  
(US) +1 702-620-5156 (UK) +44 7481 337276

## NOTES(技术要求):

- 1.Dimension after binding(装订后尺寸): 210\*297mm.
- 2.Print colour(印刷颜色): 1C.
- 3.Coating(表面处理): 无.
- 4.Material(材质): 80g offset paper (80g双胶纸).
- 5.Binding process(装订工艺): Saddle stitch(骑马钉).
- 6.Output lpi(输出网线): 200 lpi.
- 7.Tolerance(公差): L(长)\*W(宽):±1.5mm.
8. 原材料及后处理工艺均需满足RoHS环保要求。  
(Raw materials and the corresponding post processing should meet RoHS environmental protection requirements)

ITEM NAME 物料名	说明书	UNIT 单位	mm
PRODUCT TYPE 产品类别	升降桌	SCALE 比例	1:1
PROJECT NO. 项目型号	上双系列-玻璃款整板 (分包Z14D)	SHEET 页数	1/12
DESIGNED BY 设计		深圳悦孚斯科技	
REVIEW BY 审核			
DATE 日期	2023.05.04		
修改	修改内容	修改日期	制图

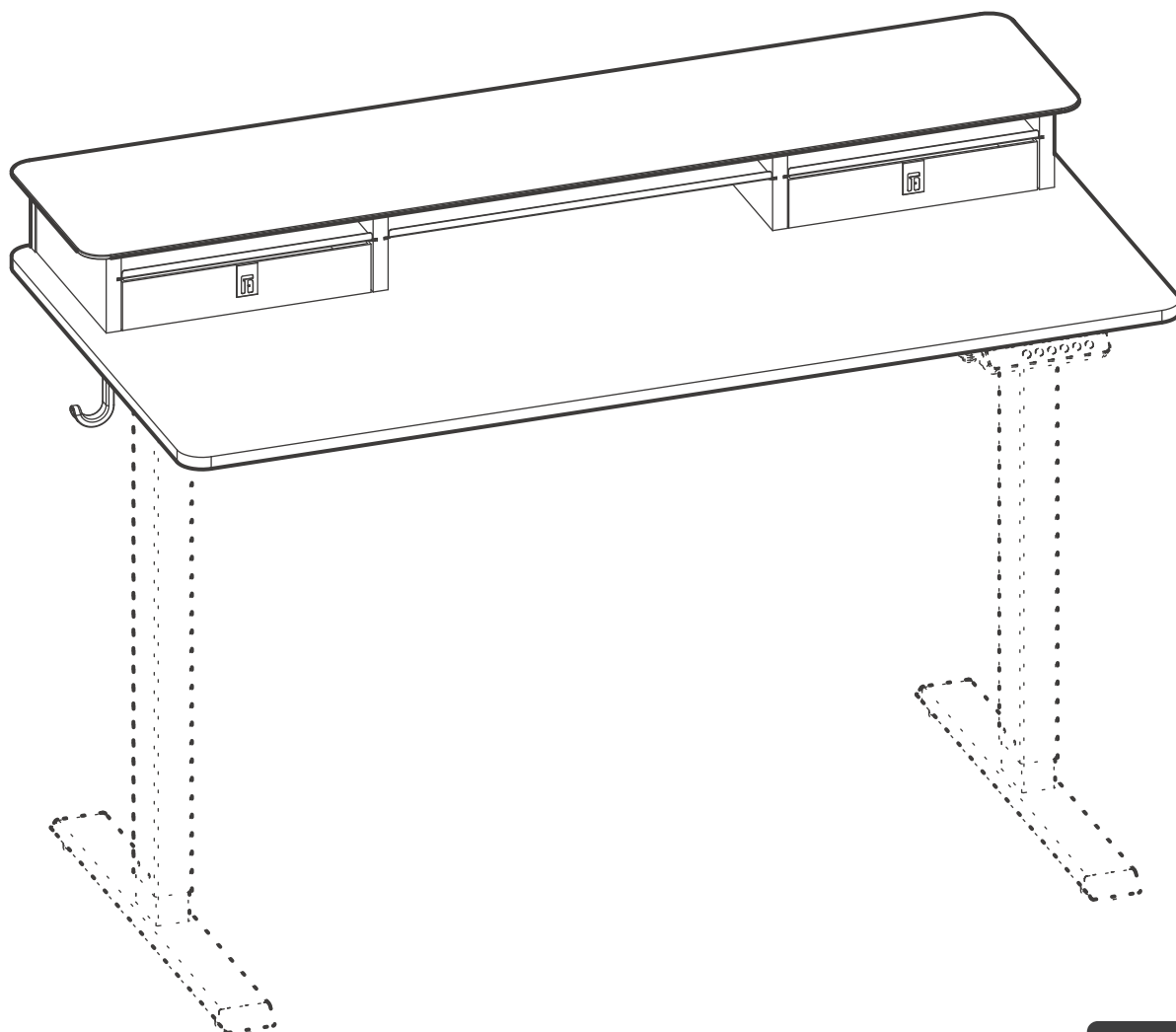
# ASSEMBLY INSTRUCTIONS



V1



**FEZiBO**

Live more, stress less.



Hours: 24/5 Mon-Fri  
(US) +1 702-620-5156

(DE) +44 7481 346904  
(UK) +44 7481 337276



## English

### Caution

- Before you begin: Lay out all parts on a clean surface to check if the tags and numbers are correct.
- Please use the screws correctly, otherwise you might damage the desk panel.
- Don't screw tightly before all the screws are put into the corresponding holes.
- Please make sure the product has been installed correctly and read the instructions before using the product.
- Do not use corrosive or abrasive materials to clean this product.
- The company does not bear any warranty or liability for damage and human injury caused by any abnormal or un-intended operation of the equipment.

## Français

### Attention

- Avant de commencer l'installation, disposez toutes les pièces sur une surface propre pour vérifier si les étiquettes et les numéros correspondent.
- Veuillez utiliser correctement les vis. Sinon, le plateau de la table pourrait être endommagé.
- Toutes les vis ne doivent pas être vissées trop fermement avant d'être placées dans les trous correspondants.
- Veuillez vous assurer que le produit a été installé correctement et lire attentivement les instructions avant d'utiliser le produit.
- N'utilisez pas de matériaux corrosifs ou abrasifs pour nettoyer ce produit.
- La société n'assume aucune garantie ou responsabilité pour les dommages et les blessures humaines causés par un fonctionnement anormal ou involontaire de l'équipement.

## Italiano

### Attenzione

- Prima di iniziare l'assemblaggio, disporre tutti i componenti su una superficie pulita per verificare che le marcature e i numeri corrispondano.
- Utilizzare correttamente le viti. In caso contrario, il piano del tavolo potrebbe subire dei danni. 3.
- Tutte le viti non devono essere serrate eccessivamente prima di inserirle negli appositi fori.
- Assicurarsi che il prodotto sia stato assemblato correttamente e leggere attentamente le istruzioni prima di utilizzarlo.
- Non utilizzare materiali corrosivi o abrasivi per pulire il prodotto.
- L'azienda non garantisce né si assume la responsabilità per eventuali danni o lesioni causati da un funzionamento anomalo o involontario del prodotto.

## Deutsch

### Vorsicht

- Bevor Sie mit dem Aufbau beginnen, legen Sie alle Teile auf einer sauberen Oberfläche aus, um zu prüfen, ob die Kennzeichnungen und Nummern übereinstimmen.
- Bitte verwenden Sie die Schrauben richtig. Andernfalls könnte die Tischplatte beschädigt werden.
- Alle Schrauben sollten nicht zu fest angezogen werden, bevor sie in die entsprechenden Löcher gesteckt werden.
- Vergewissern Sie sich, dass das Produkt korrekt aufgebaut wurde, und lesen Sie die Anweisungen sorgfältig durch, bevor Sie das Produkt verwenden.
- Verwenden Sie keine ätzenden oder scheuernden Materialien zur Reinigung dieses Produkts.
- Das Unternehmen übernimmt keine Garantie oder Haftung für Schäden und Verletzungen, die durch einen abnormalen oder unbeabsichtigten Betrieb des Geräts verursacht werden.

## Español

### Precaución

- Antes de comenzar la instalación, extienda todas las piezas sobre una superficie limpia para comprobar si las etiquetas y los números se corresponden.
- Por favor, utilice correctamente los tornillos. De lo contrario, el tablero de la mesa podría resultar dañado.
- Todos los tornillos no deben atornillarse con demasiada fuerza antes de introducirlos en los agujeros correspondientes.
- Por favor, asegúrese de que el producto ha sido instalado correctamente y lea atentamente las instrucciones antes de utilizarlo.
- No utilice materiales corrosivos o abrasivos para limpiar este producto.
- La empresa no garantiza ni se responsabiliza de los daños y perjuicios causados por un funcionamiento anormal del producto o se causado accidentalmente por el producto.

## 日本語

### 注意

- 取り付ける前に全ての部品を取り外してきれいな面に並んで、タグと個数を確認してください。
- ネジは正しく使用しないと、デスクパネルが破損することがあります。
- ネジを対応する穴に入れる前に、強く締めしないでください。
- ご使用の前に、商品を正しく組み立てられていることを確認し、説明書をよくお読みください。
- 腐食剤と研磨剤で本商品を清掃しないでください。
- 機器の異常や意図しない動作によって生じた損害や人身事故について弊社は一切の保証や責任を負いかねます。

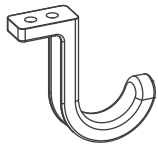
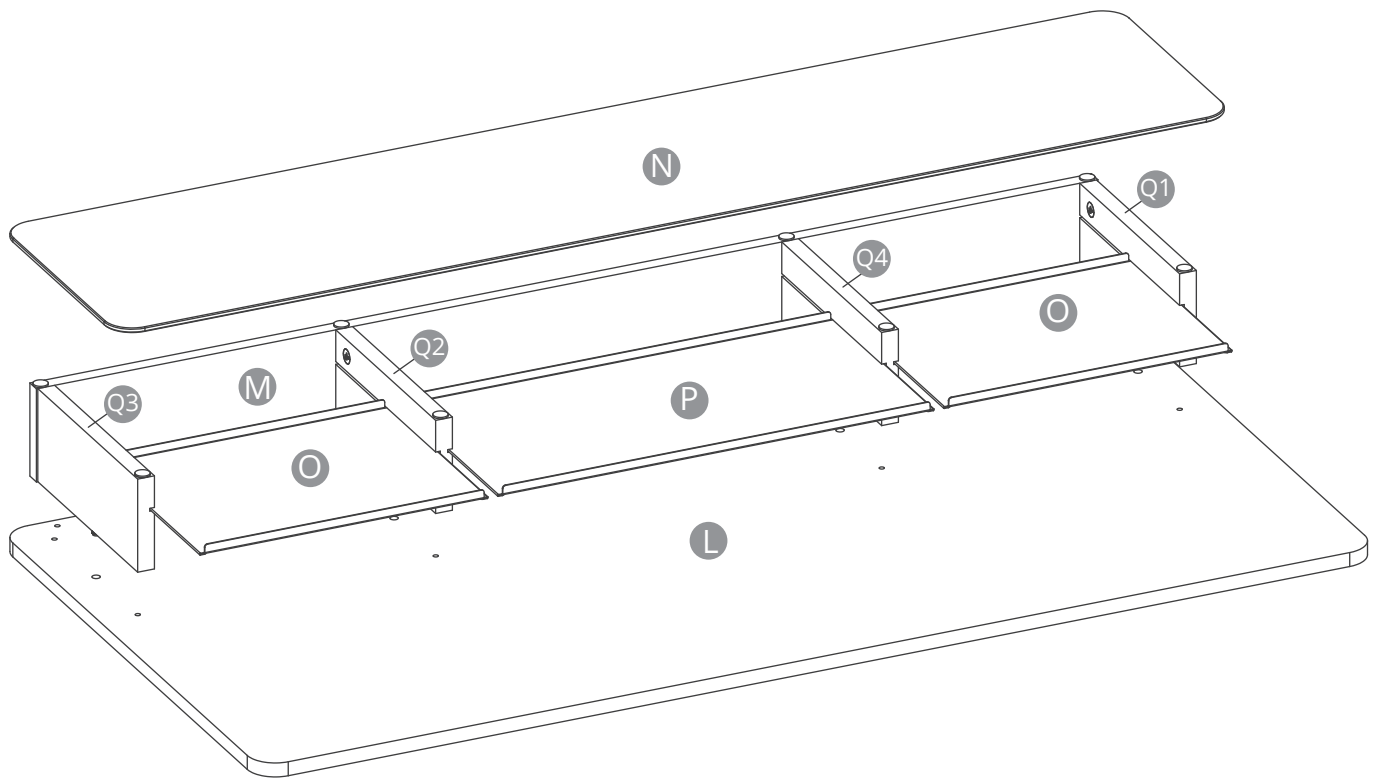

R x2



T x8

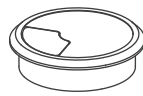

U x1

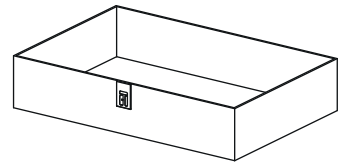

V x2

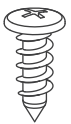

M5x14

① x4

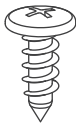

M5x14

② x10



③ x10

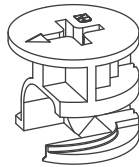

④ x4



⑤ x4

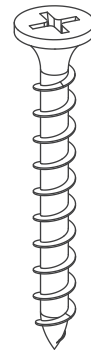

M4x35

⑥ x11

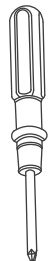

⑦ x1

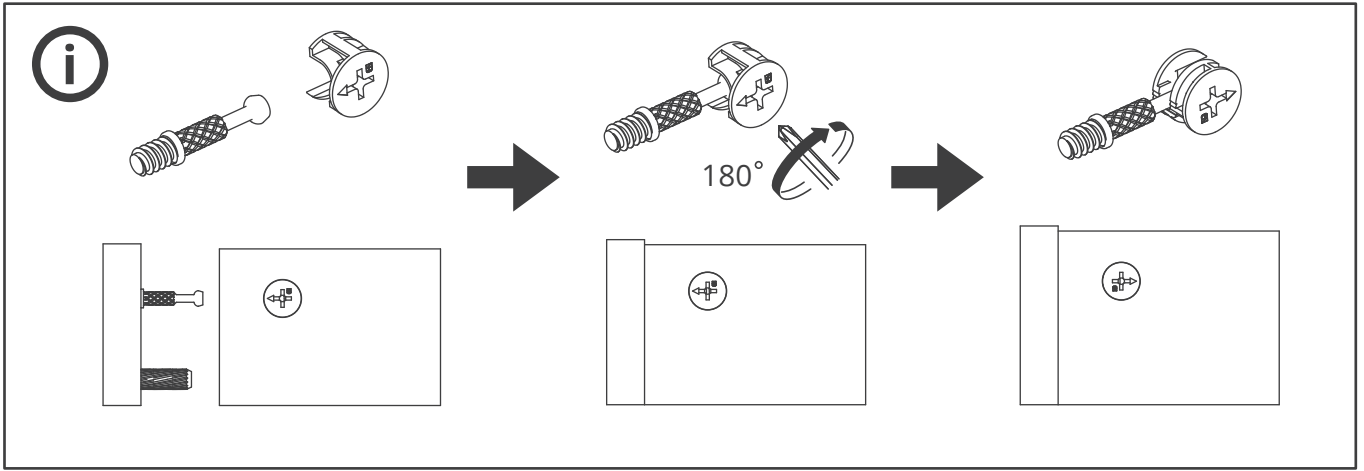

**1**

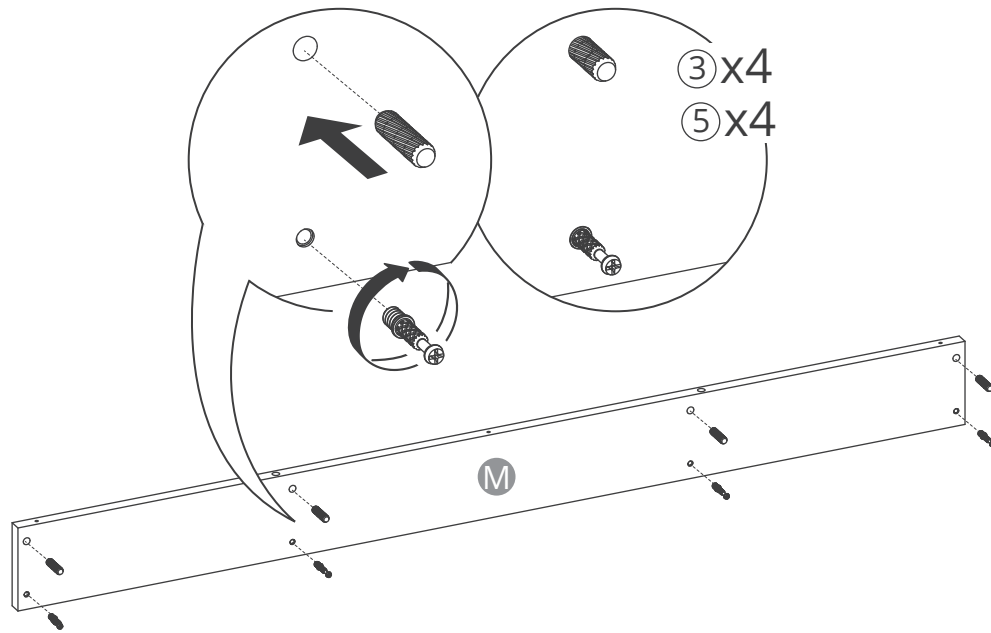

**2**

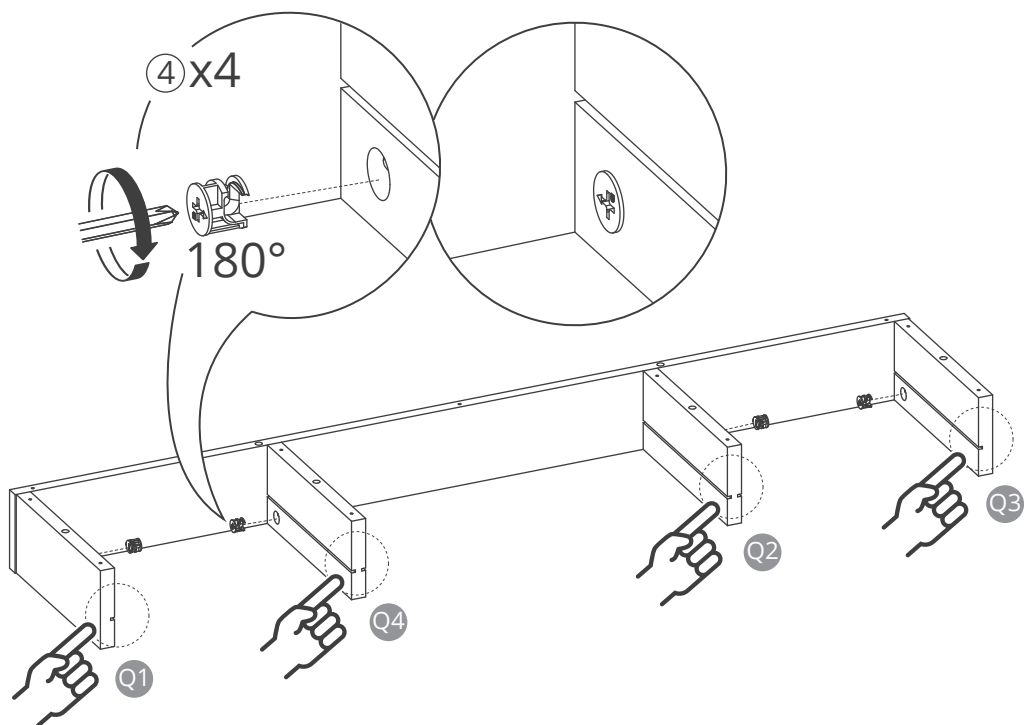

3

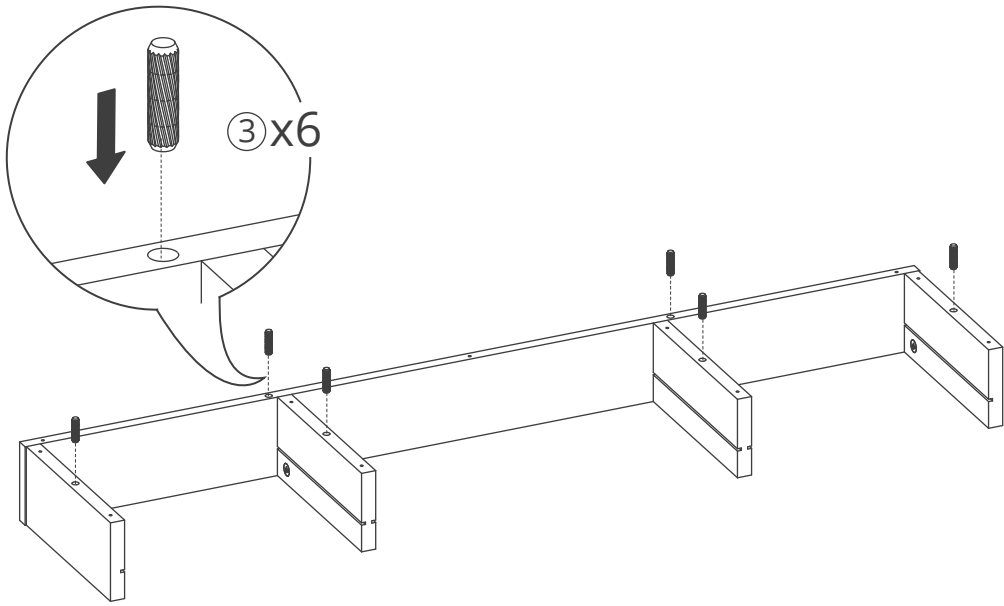

4

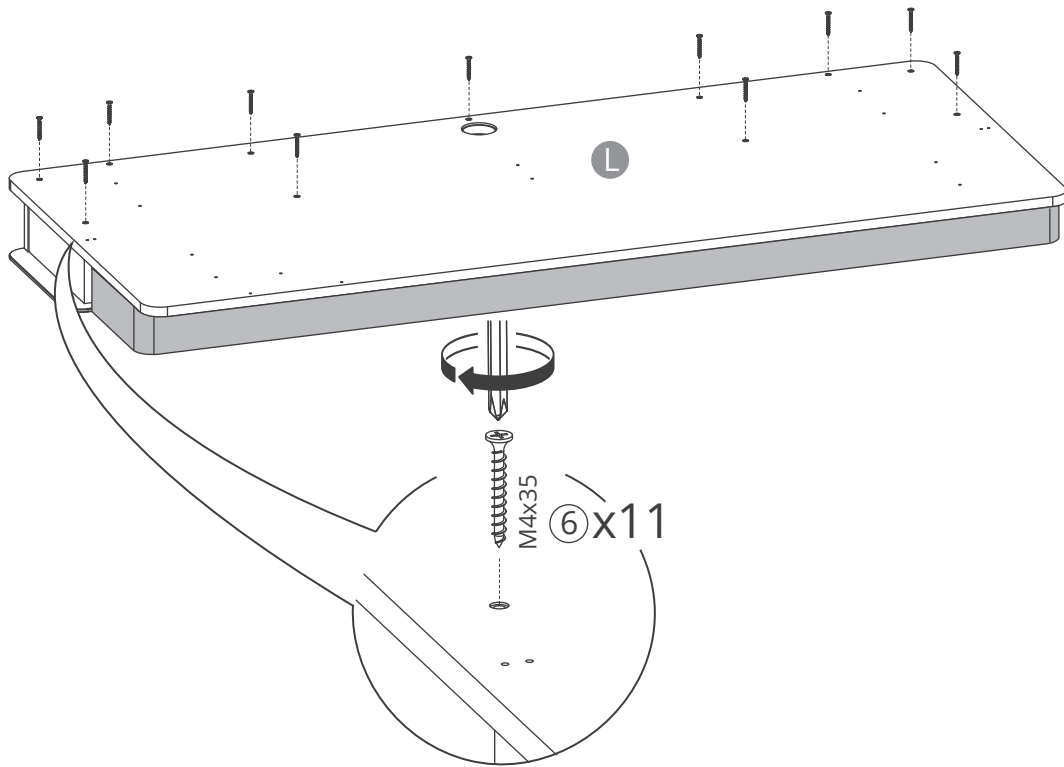

5

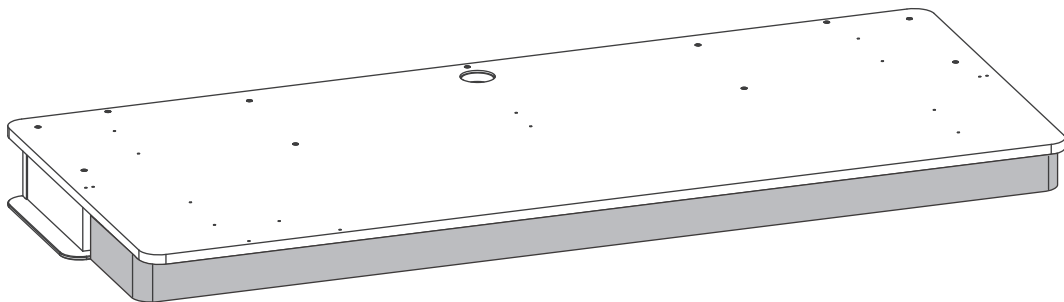



## ASSEMBLY INSTRUCTIONS

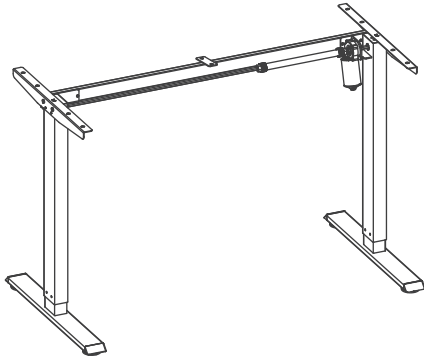

### **Please note:**

the deskframe above is for assembly reference only.  
The actual deskframe is subject to your own selection.

### **Achtung:**

Der obere Rahmen des Tisches ist nur für Referenz des Aufbaues.  
Bitte wählen Sie Ihren eigenen Rahmen.

### **Veillez noter :**

le cadre de bureau ci-dessus est pour référence d'assemblage uniquement.  
Le cadre de bureau réel est soumis à votre propre sélection.

### **Tenga en cuenta:**

el marco de escritorio arriba es solo para la referencia de ensamblaje.  
El marco de escritorio real está sujeto a su propia selección.

### **Nota:**

Il telaio della scrivania mostrato sopra costituisce solo un riferimento per il montaggio.  
Il telaio effettivo della scrivania è determinato dalla vostra scelta.

6

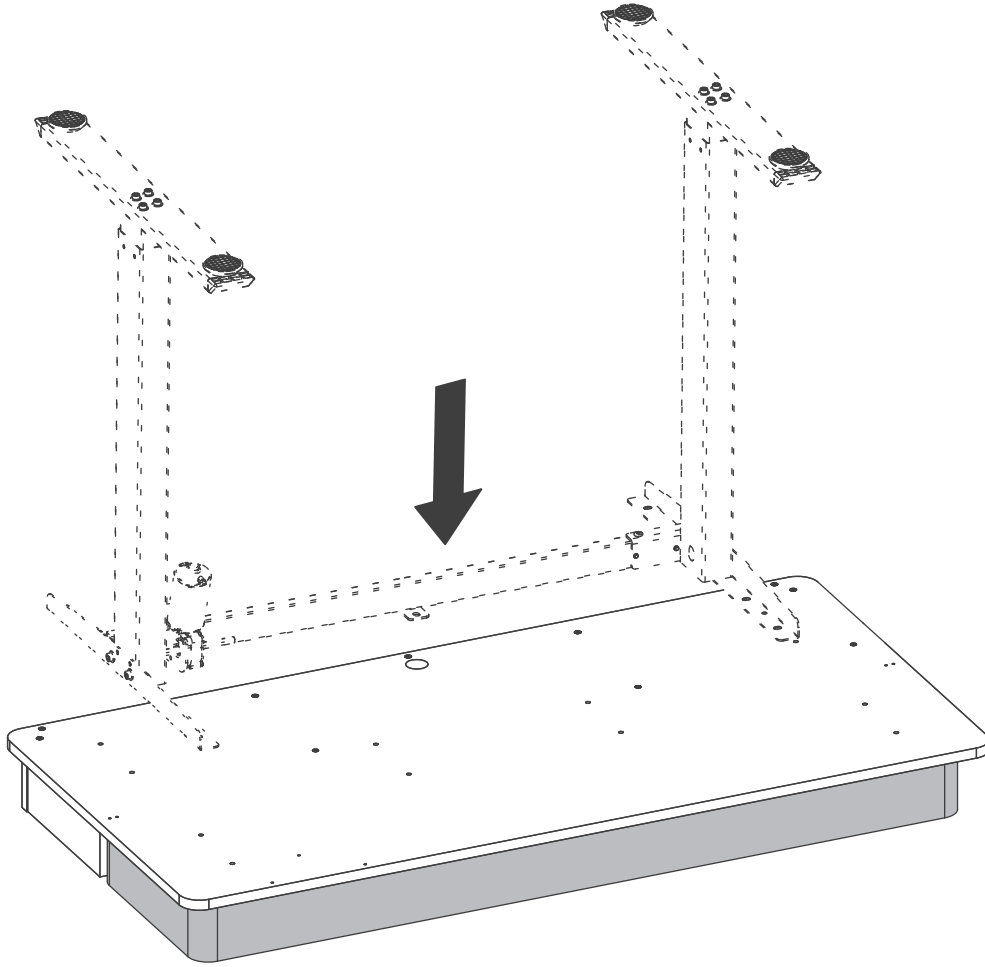

7

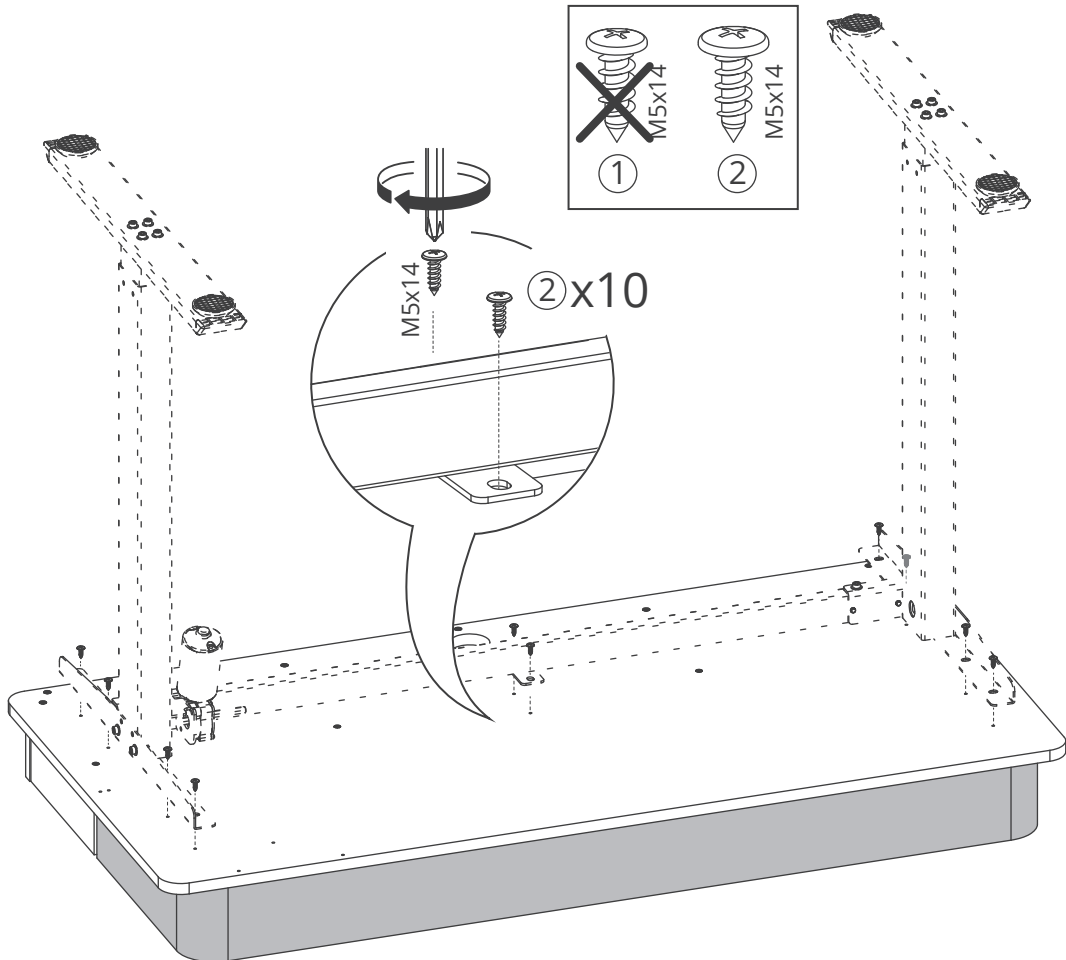



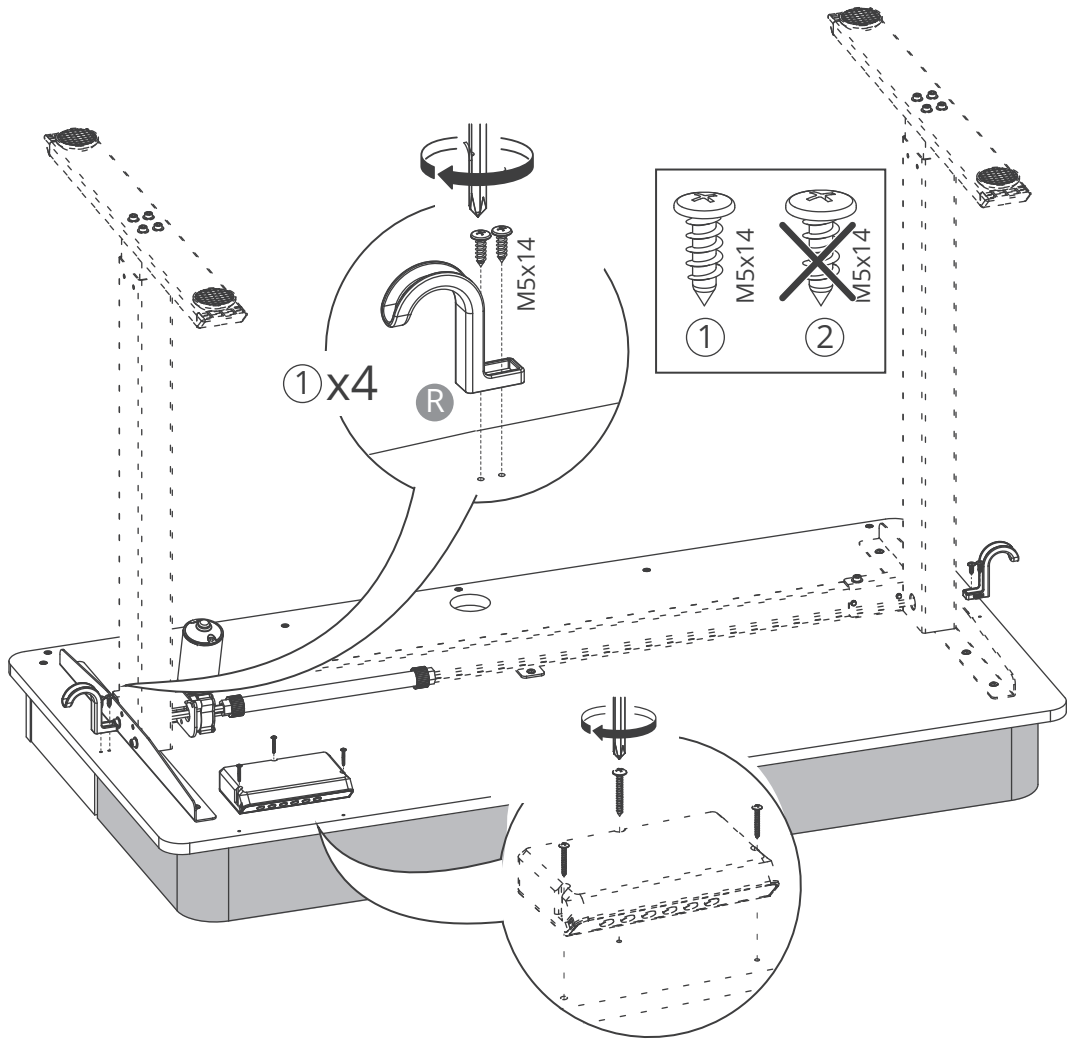

9

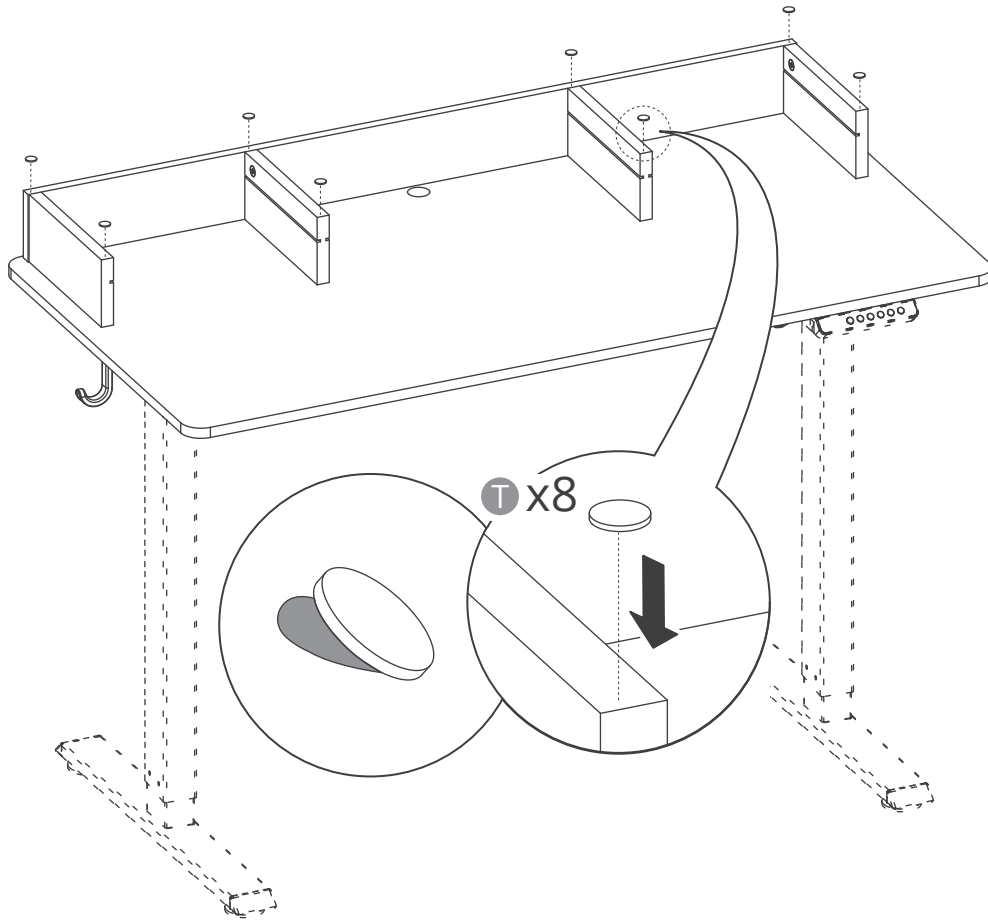

10

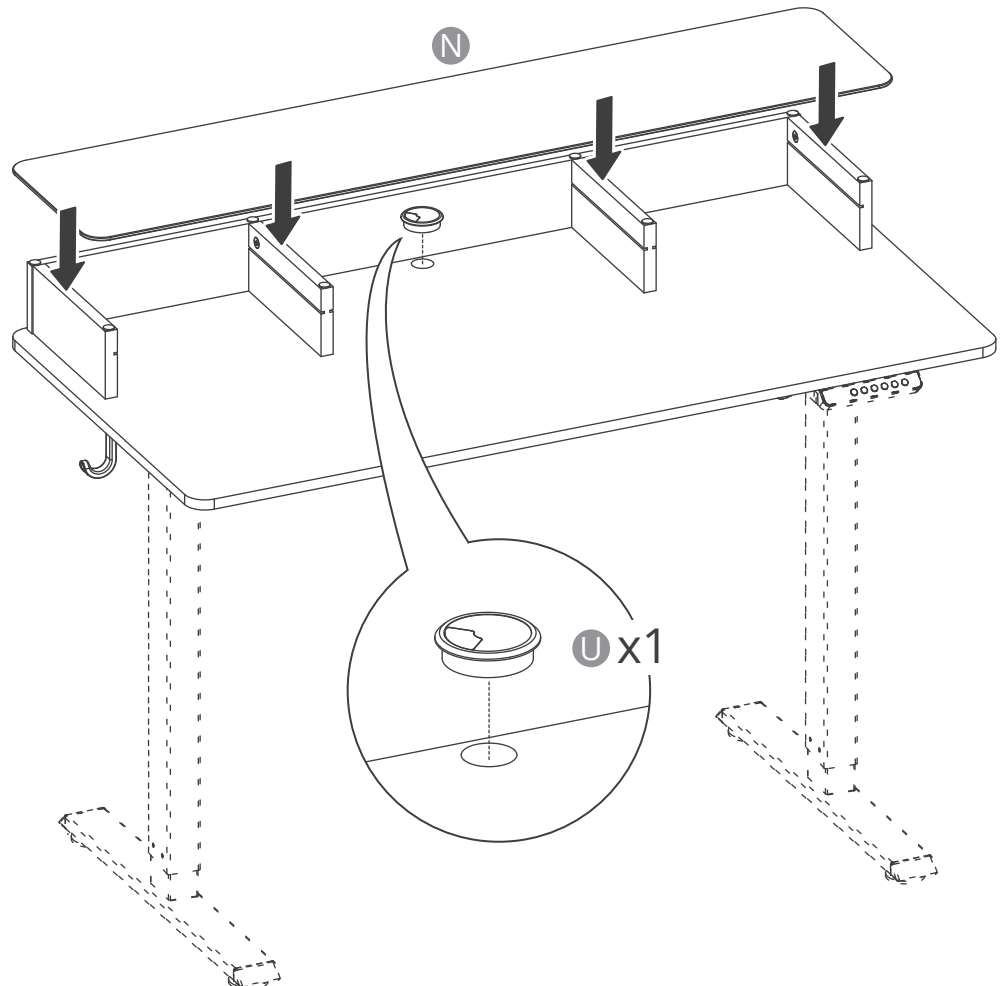

# 11

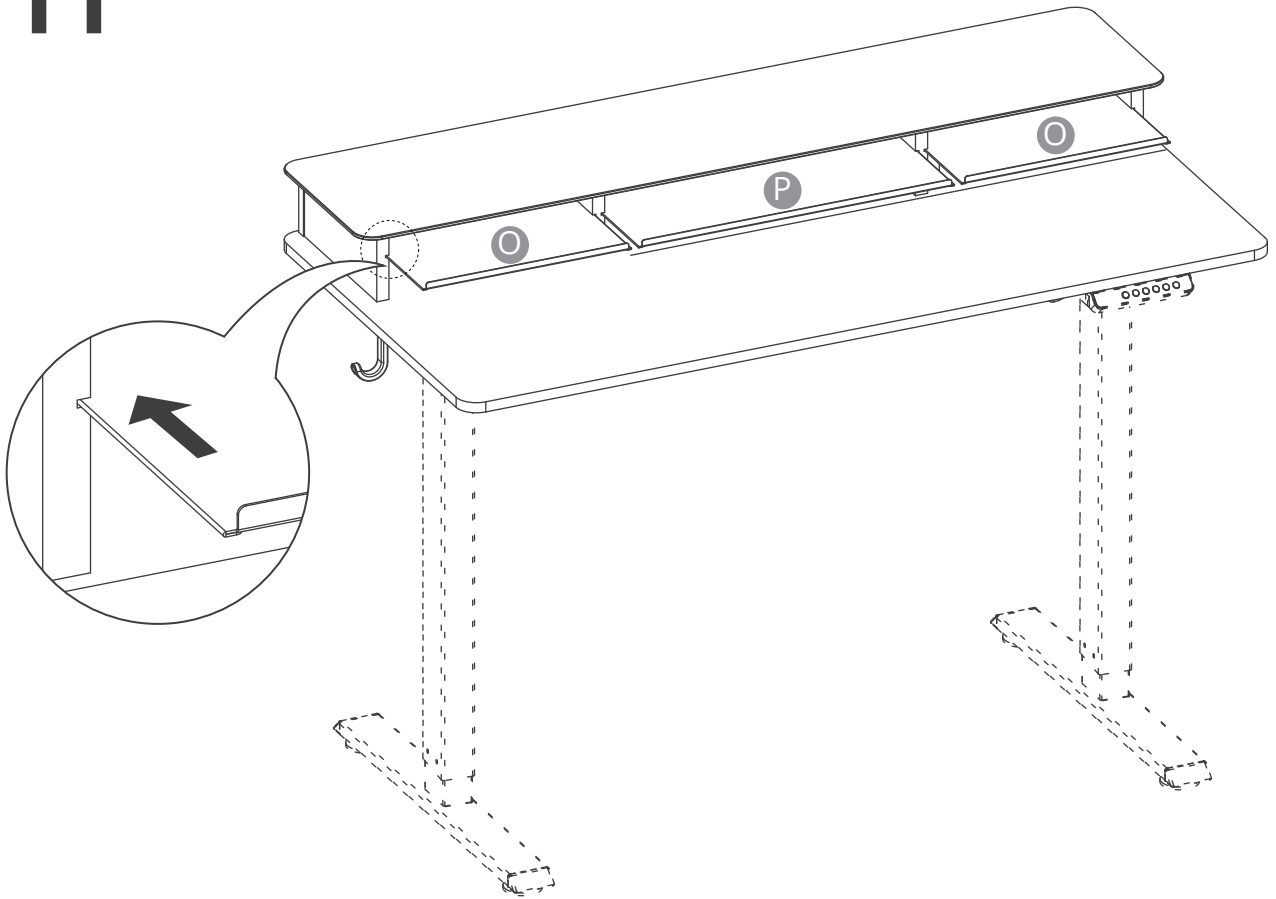

# 12

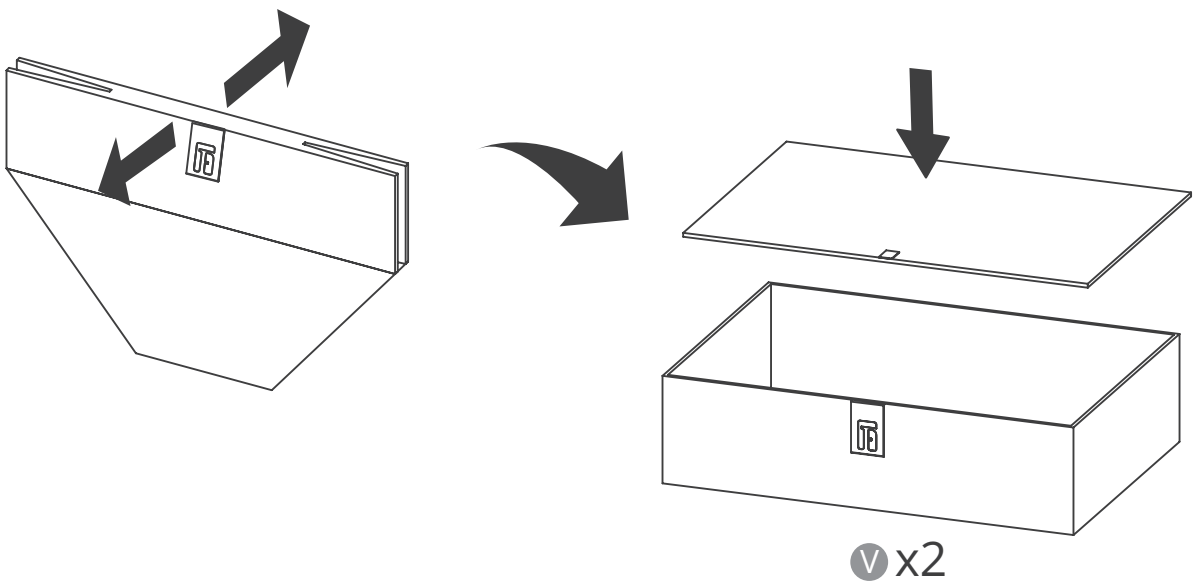

# 13

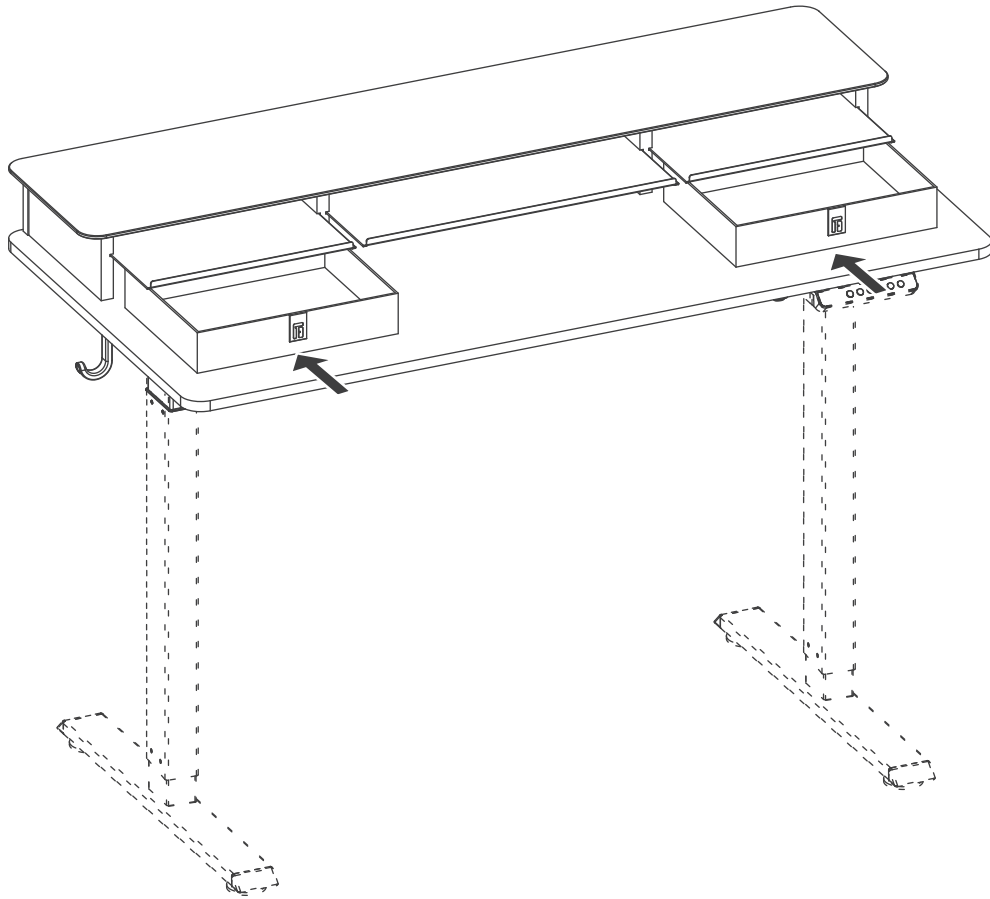

# 14

