

VERNAL

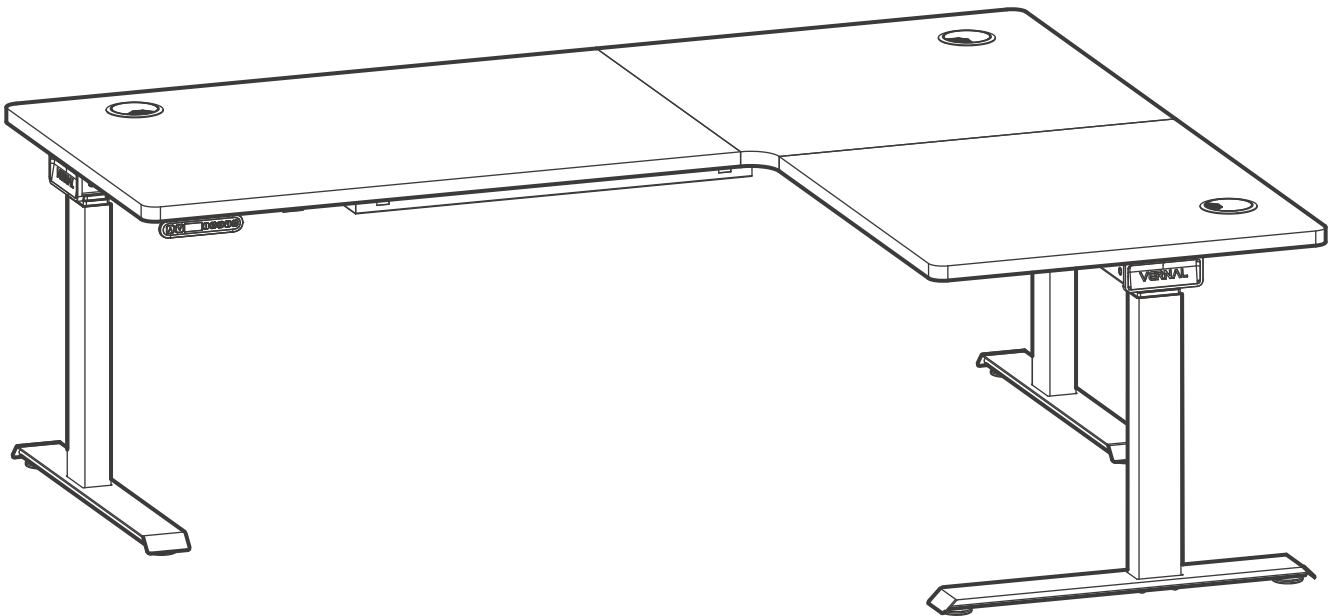

ASSEMBLY INSTRUCTIONS



This manual is only applicable for assembling the entire desk (i.e., the frame and desktop). However, if you have purchased a desk shell, please follow the specific instructions in the included manual to assemble the product.

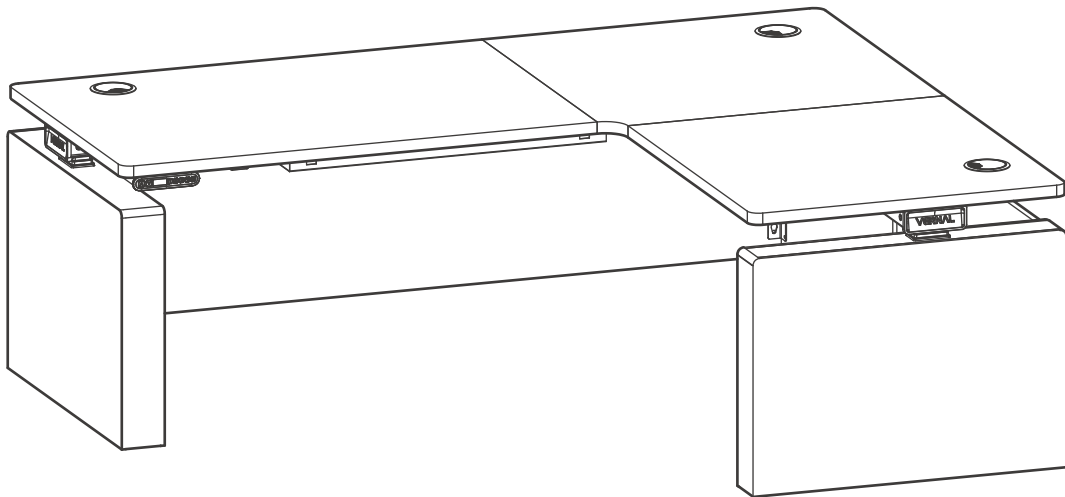

English

Caution

- Keep children and animals away from the desk during use. Ensure the desktop is not touching any walls.
- Remove obstacles taller than 20"/51 cm from underneath the desk.
- Operate only in a working environment temperature of 32°F-104°F/0°C-40°C.
- Keep product away from corrosive gases, liquids and dusty objects.
- Keep hands, feet and other body parts in a safe position during operation. Anti-collision is not automatically enabled during all resets.
- The company does not bear any warranty or liability for damage and human injury caused by any abnormal or un-intended operation of the equipment.
- It is necessary to perform a manual reset after the initial installation or power cycling the equipment.

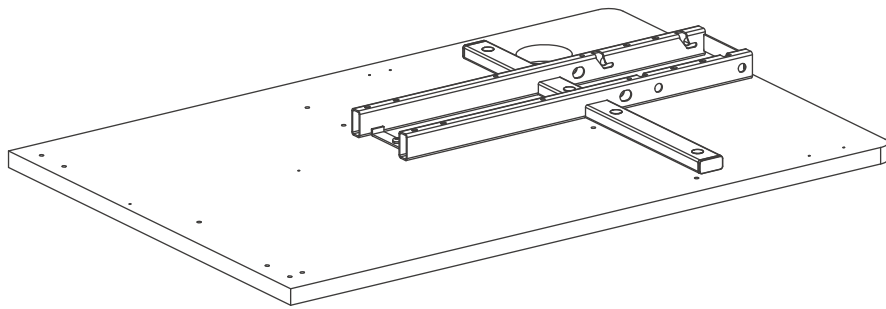

18R1 / 15R1

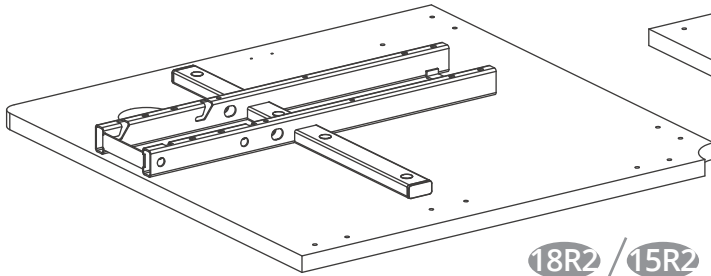

18R2 / 15R2

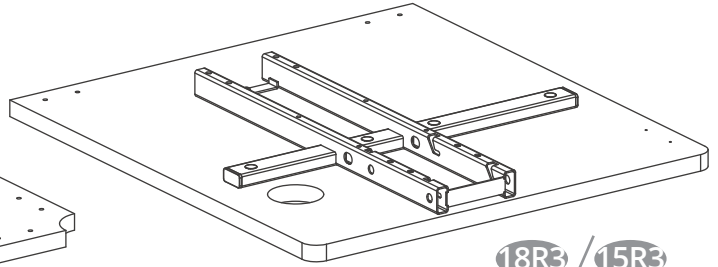

18R3 / 15R3

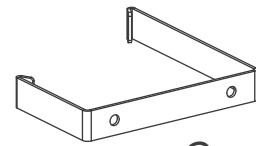
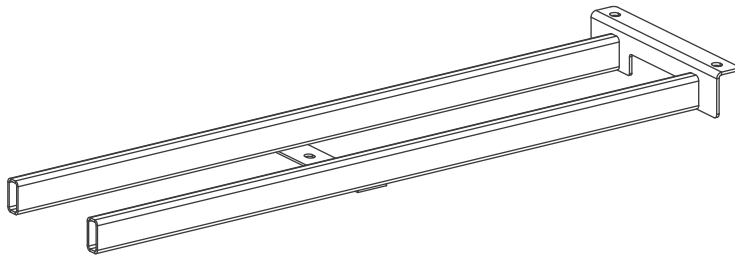

x2

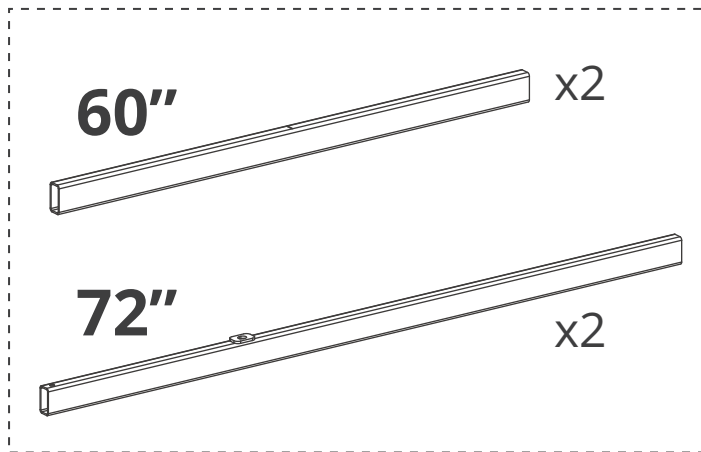

60"

x2

72"

x2

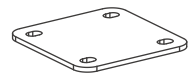
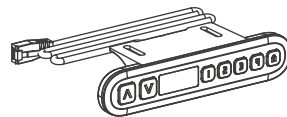
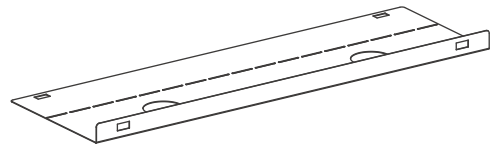

x4

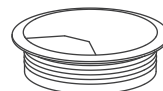
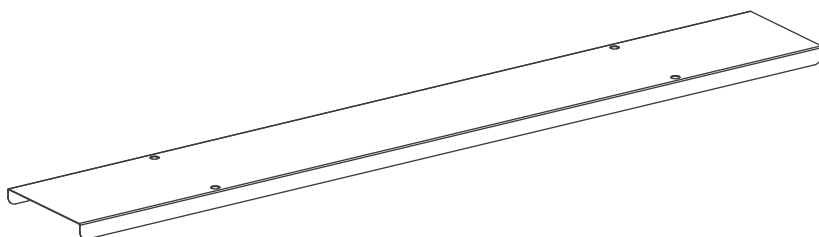

x3



x3

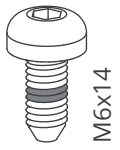

A16 x48



A14 x4



D13 x4



J11 x8

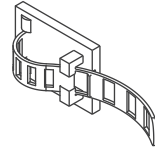

G02 x7

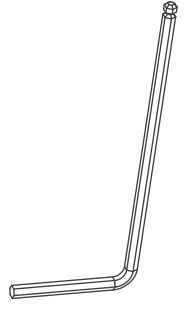

E08

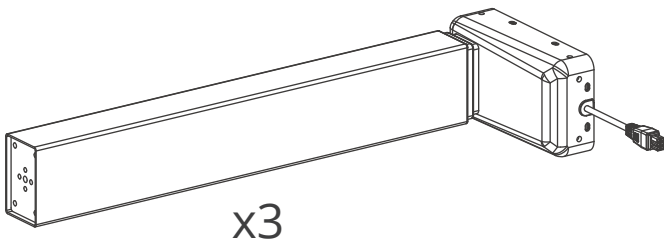
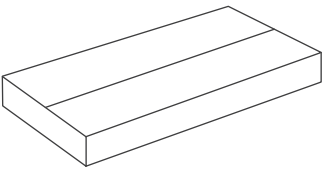

x3

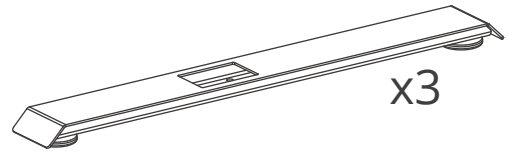

x3

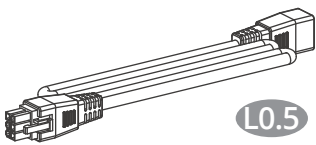

L0.5

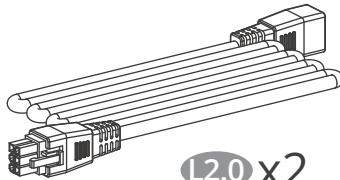

L2.0 x2

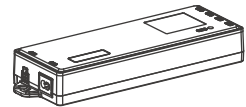
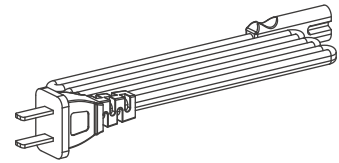

1

60"

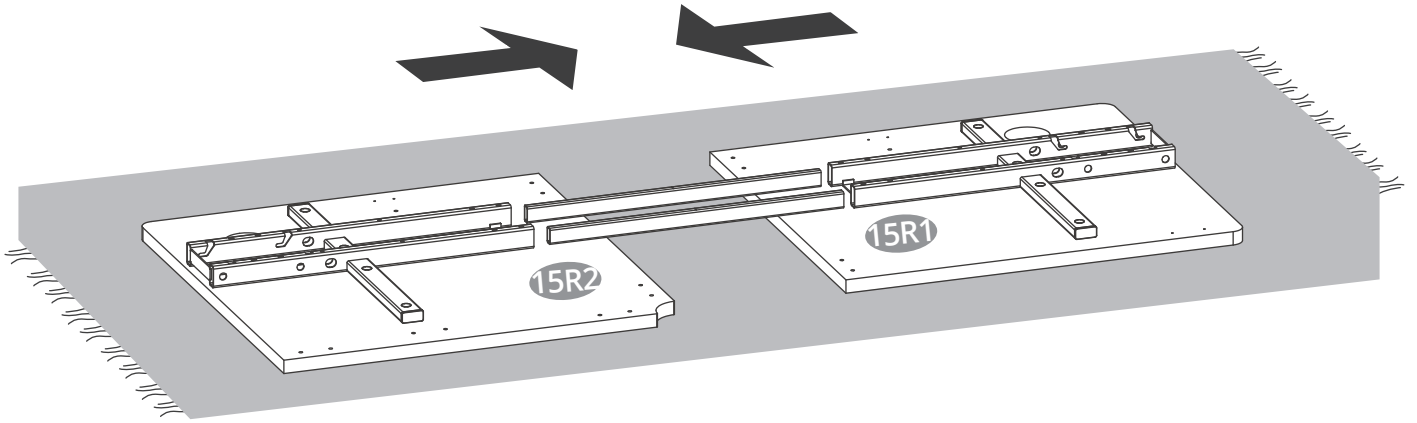

72"

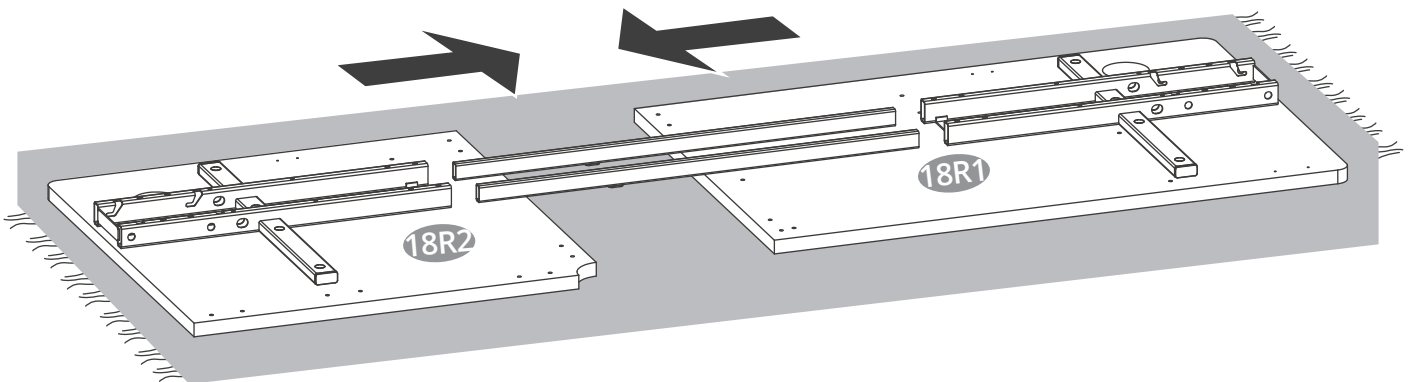

2

60"

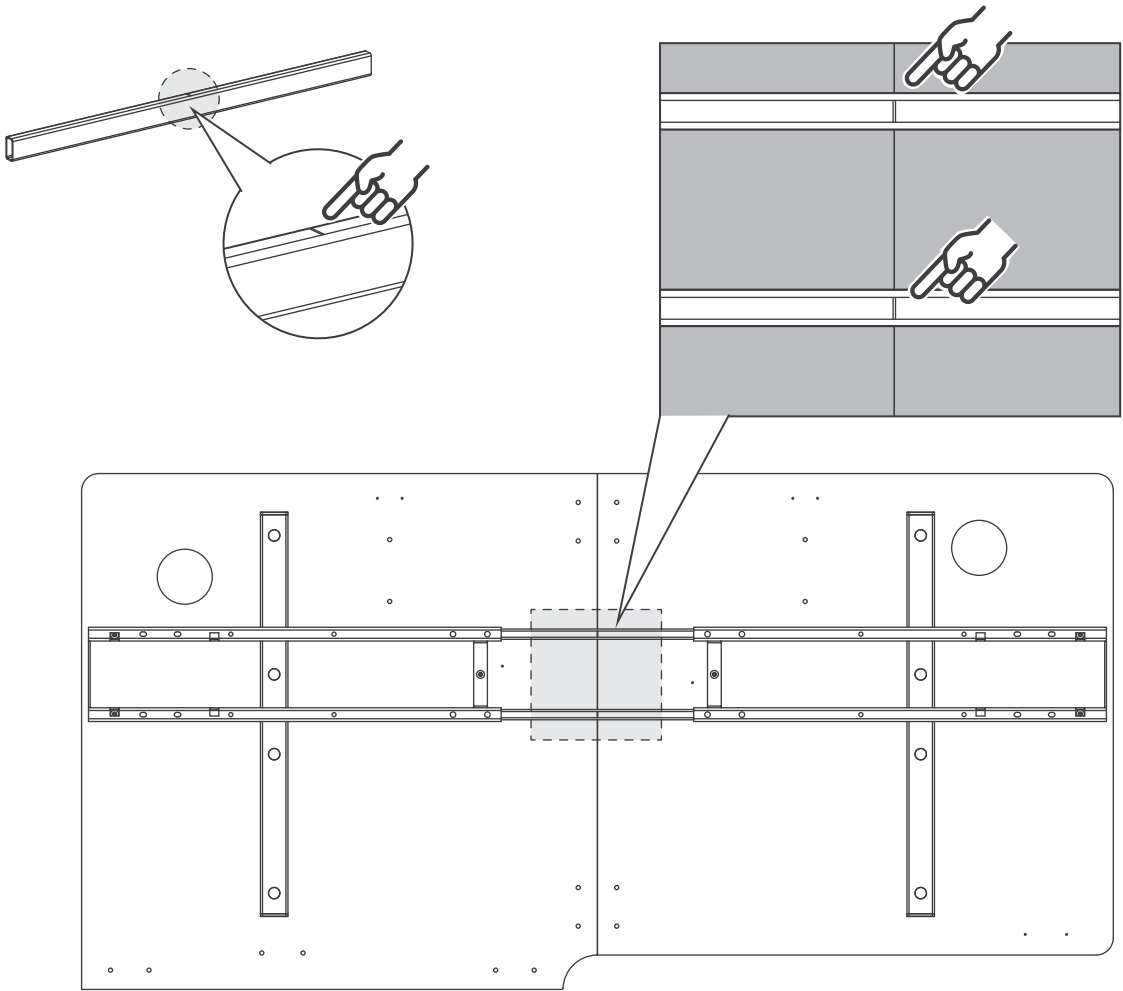

72"

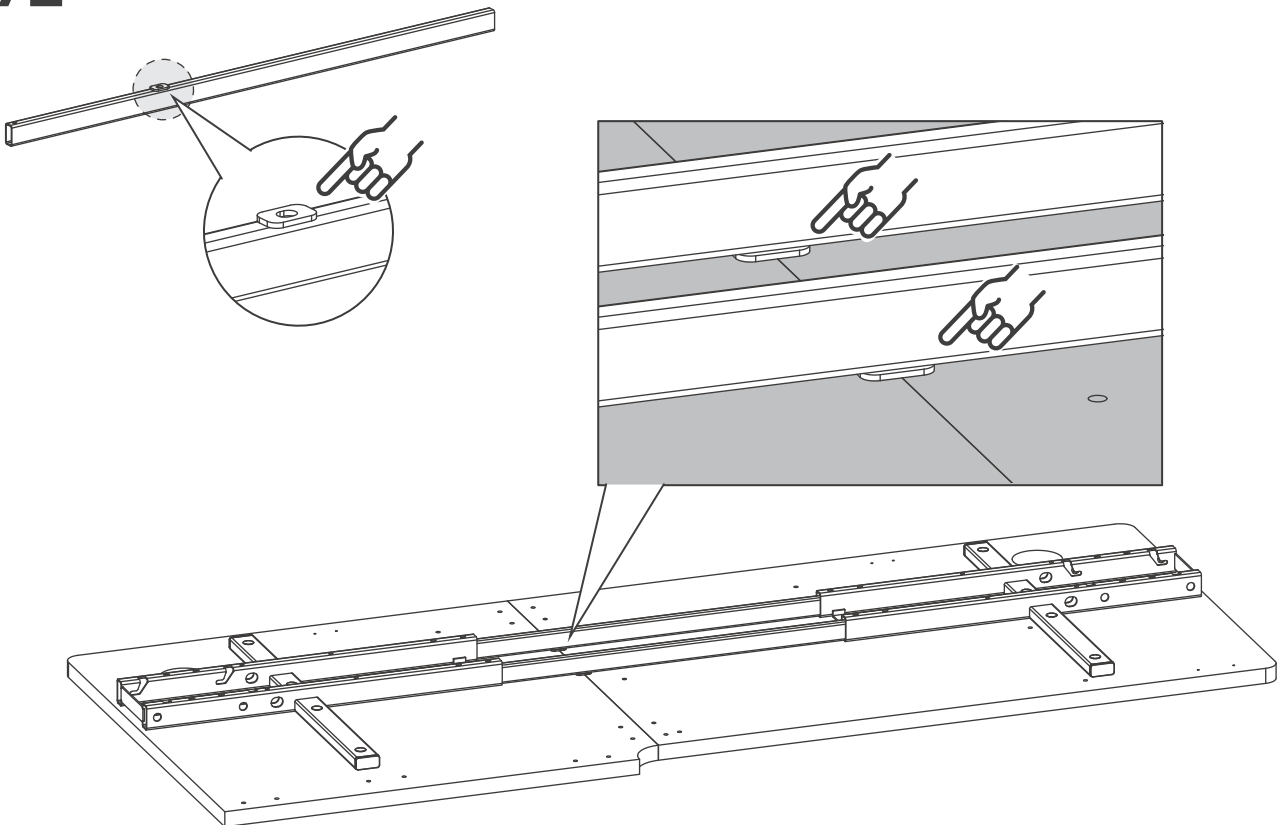

3

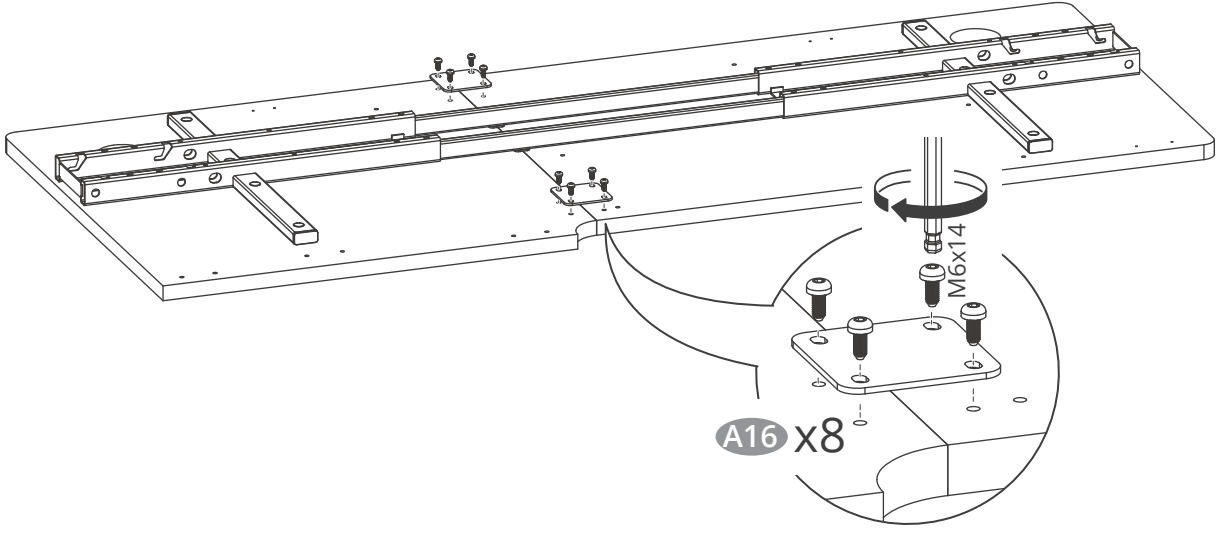

4

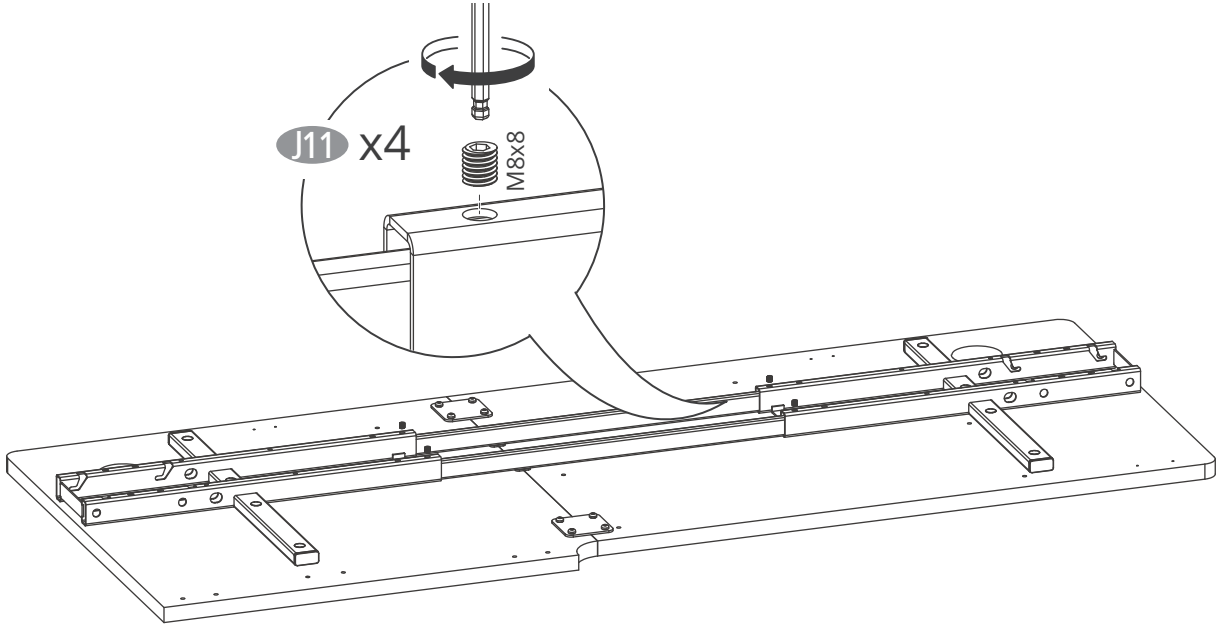

5

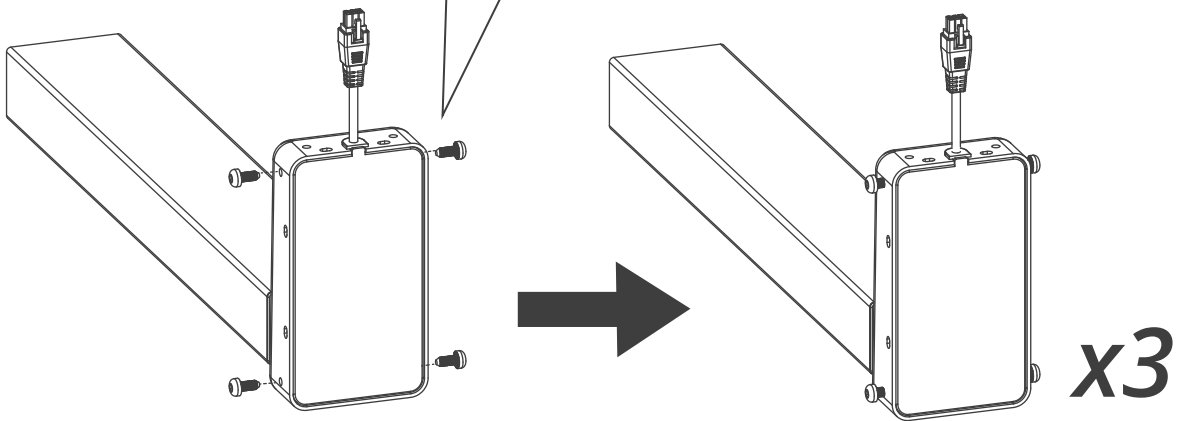
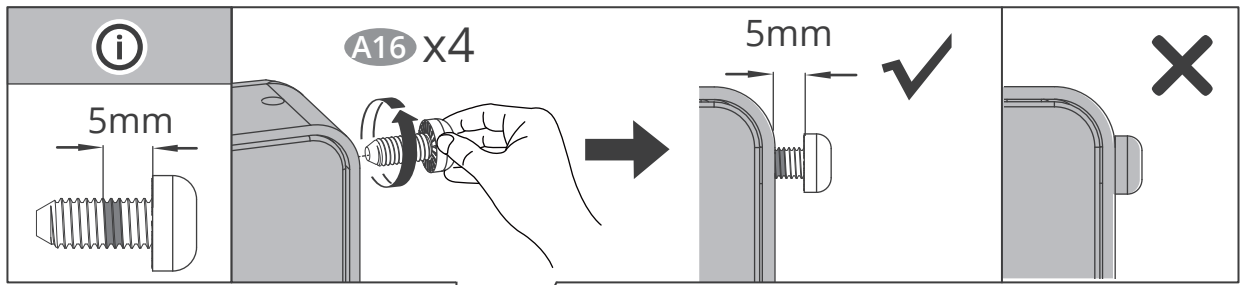

6

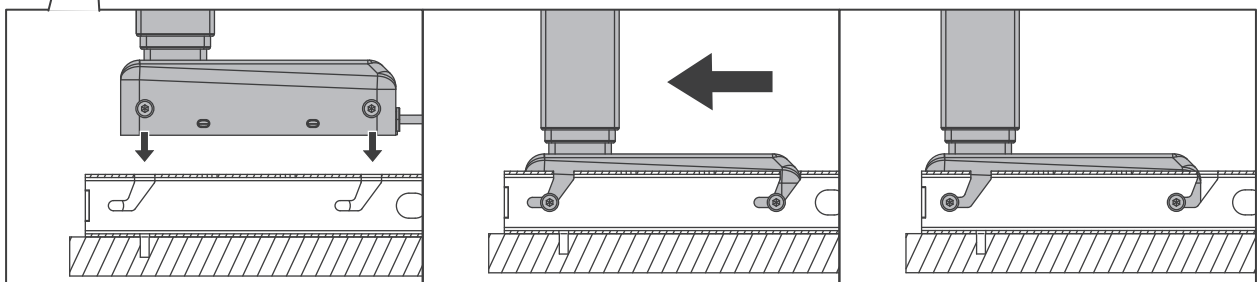
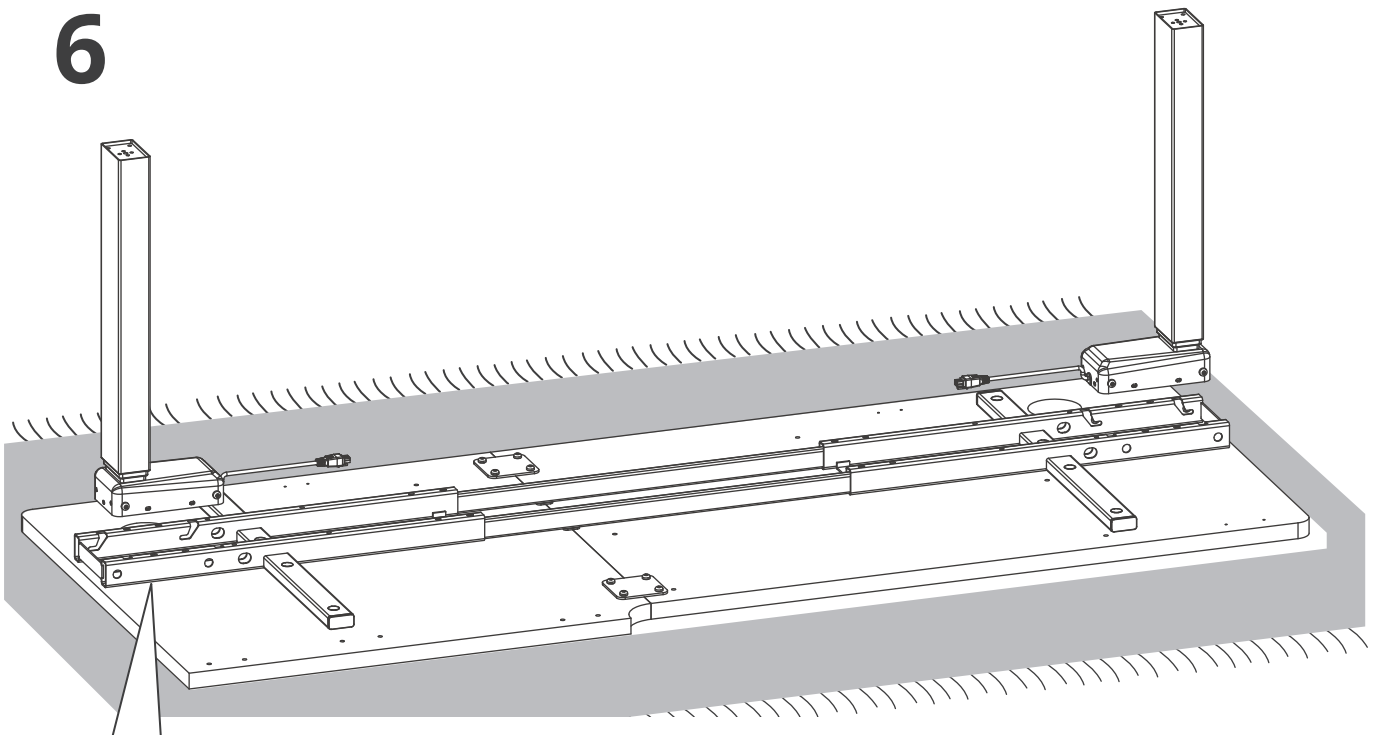

7

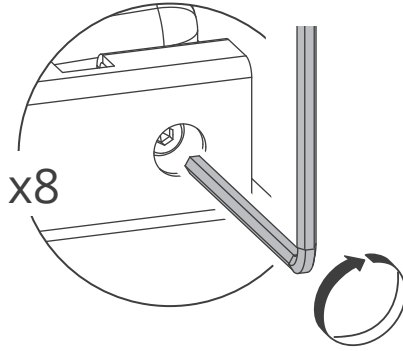

i Locking sequence of 8 screws.

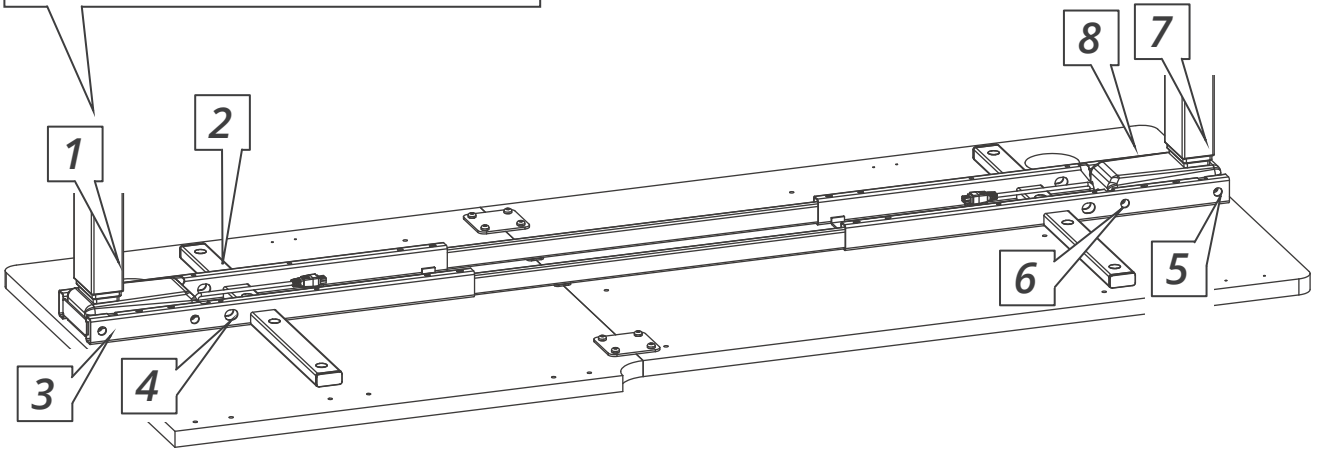

8

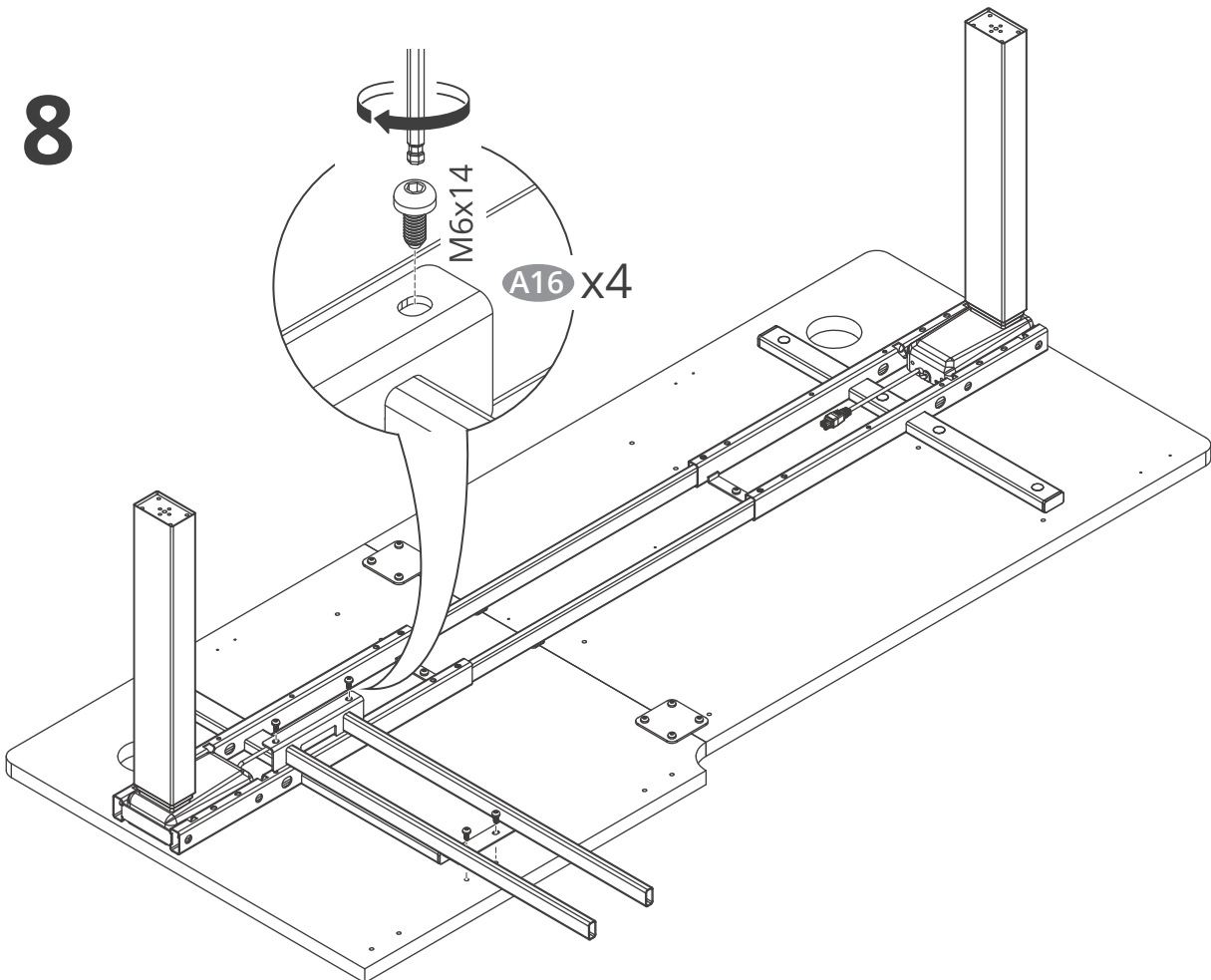
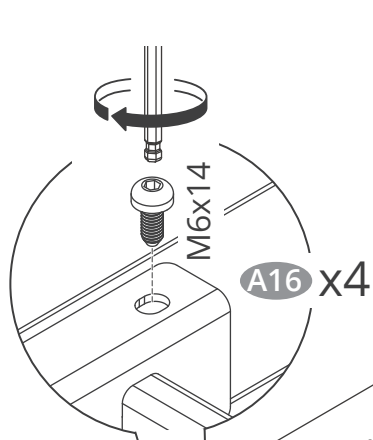

9

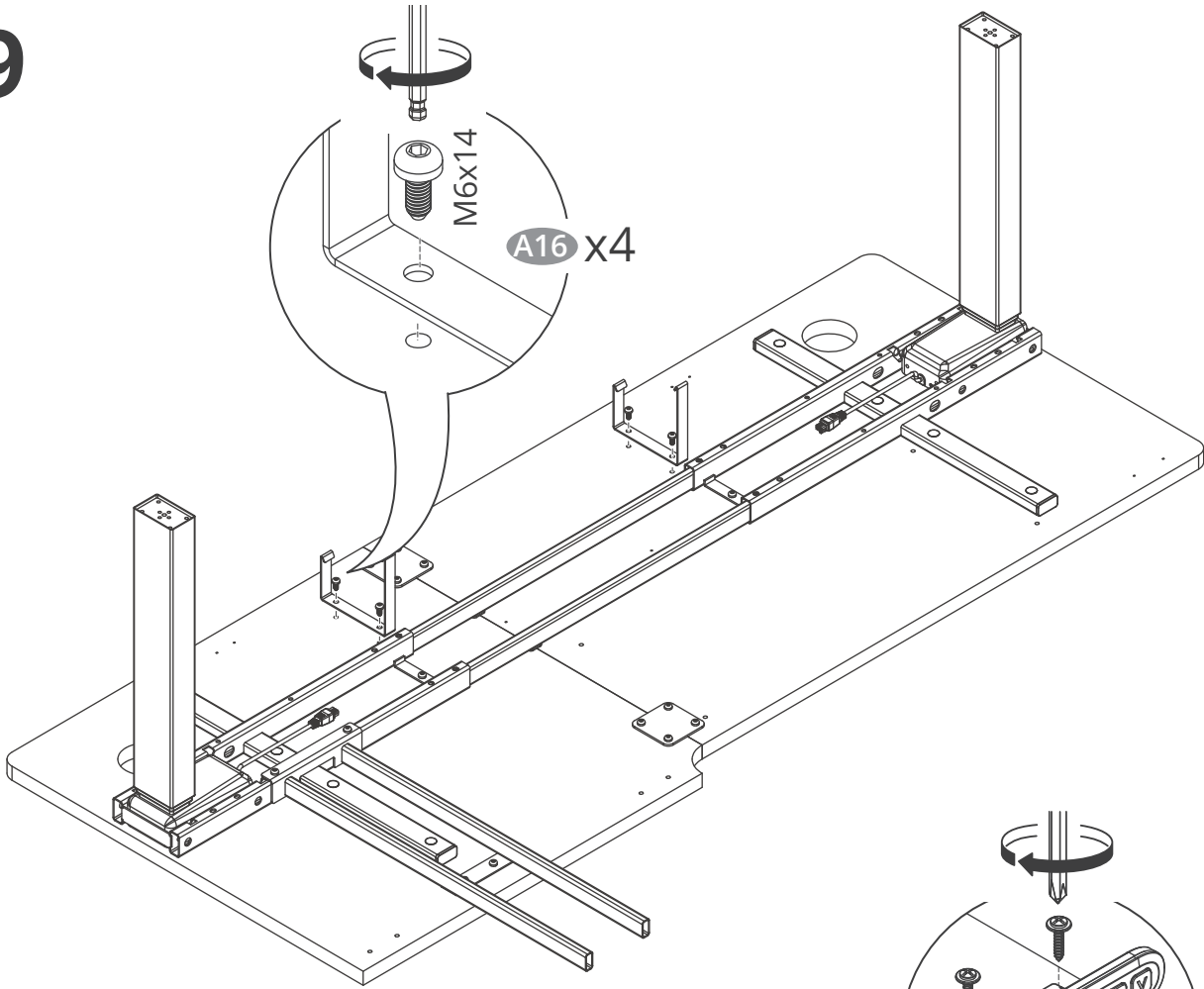

10

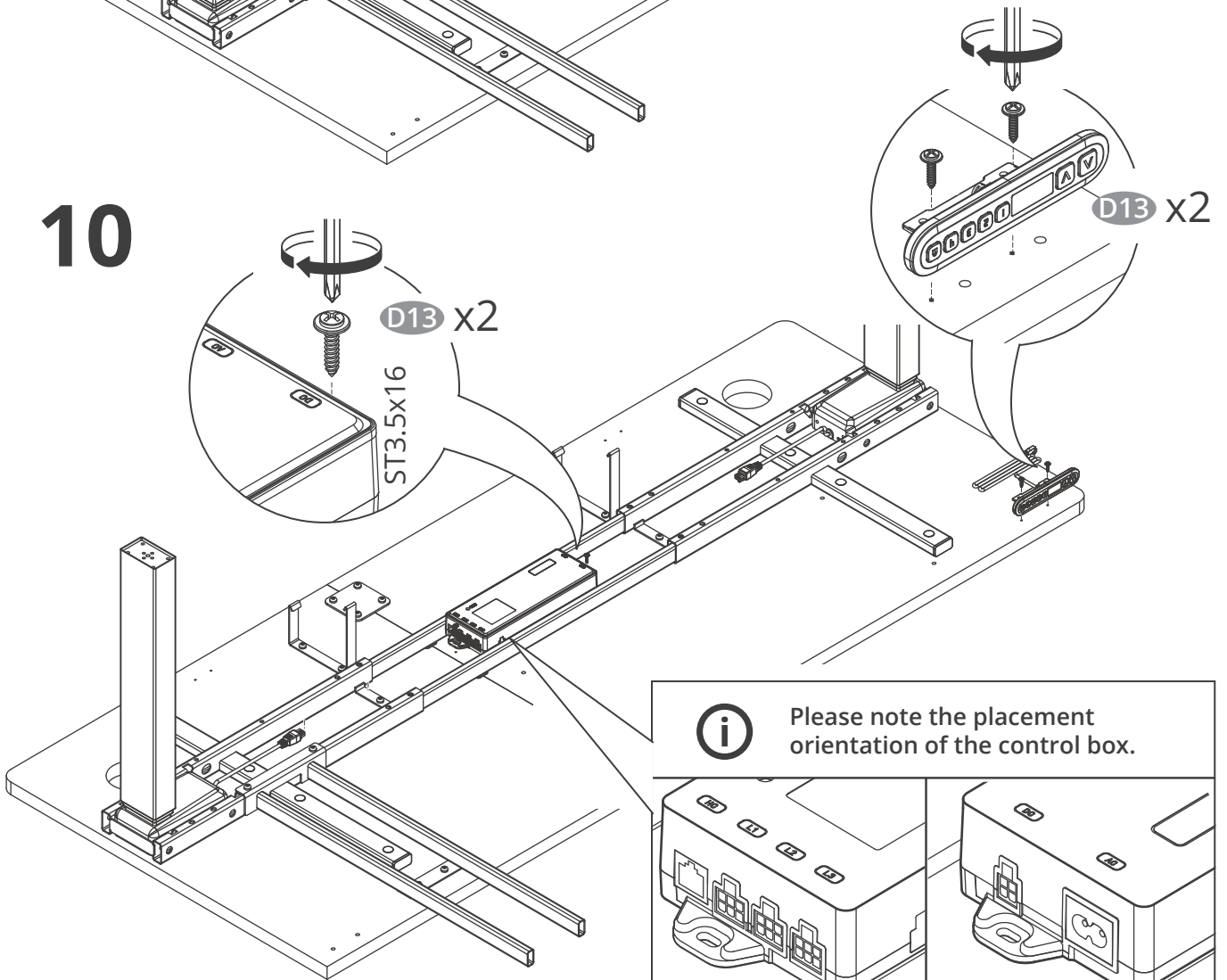

Please note the placement orientation of the control box.

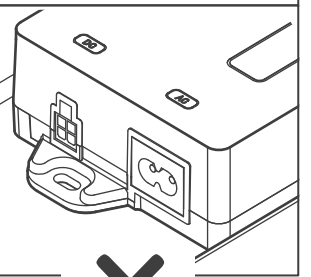
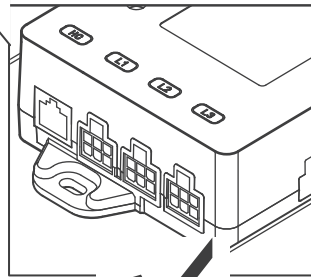

11



The power cable needs to pass through the hole where the arrow points to the steel frame.

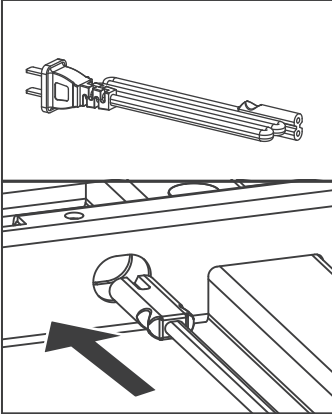

The controller cable needs to pass through the hole where the arrow points to the steel frame.

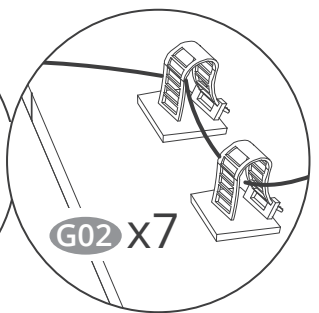
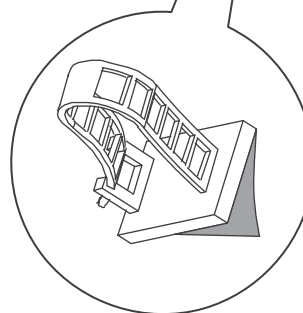
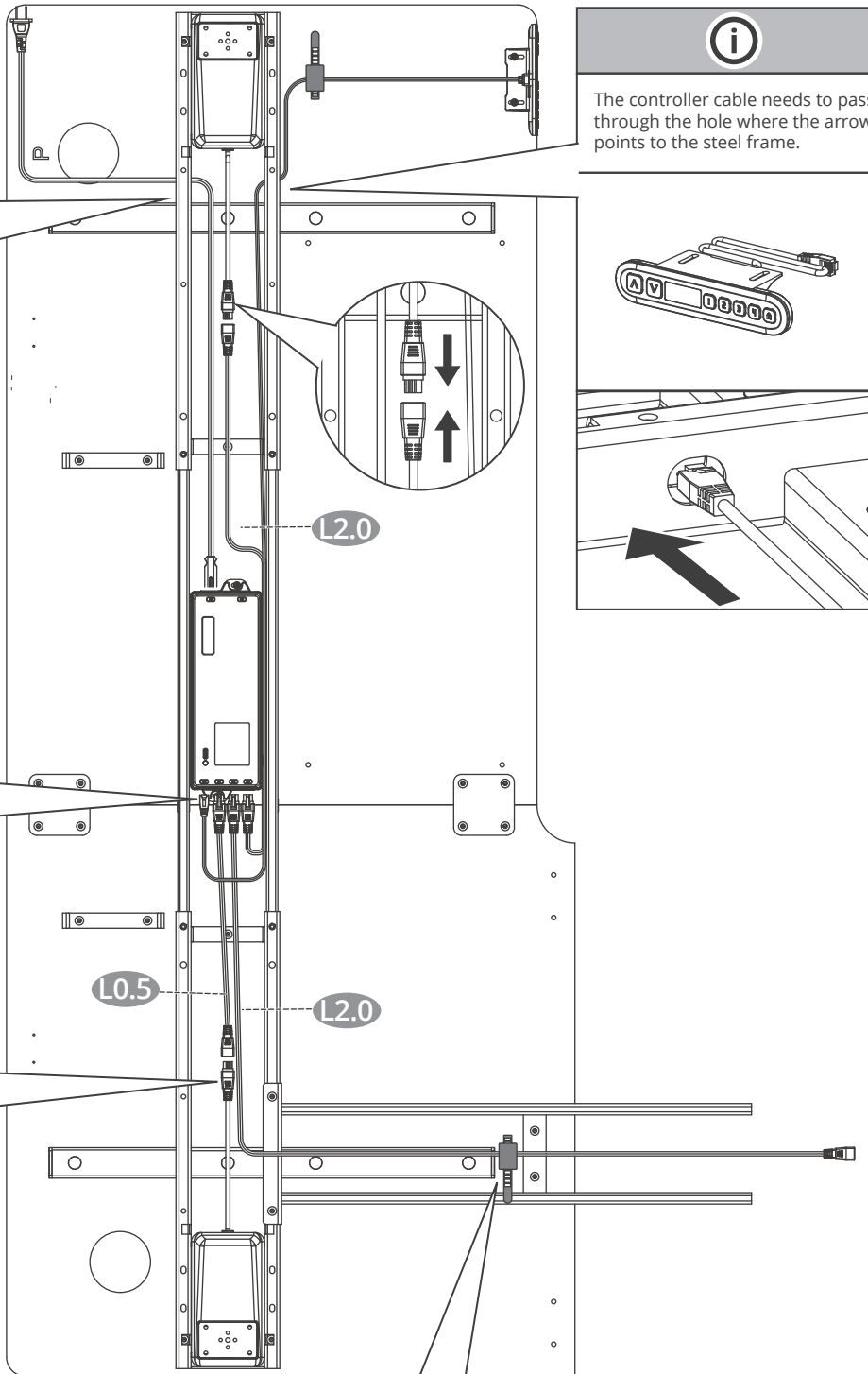
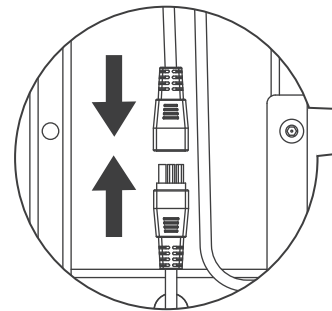
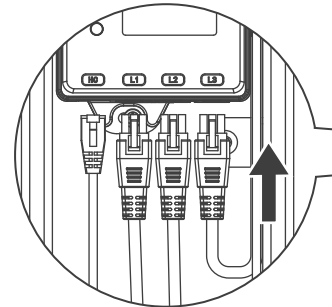
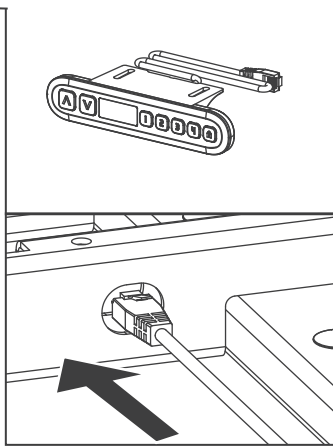

12

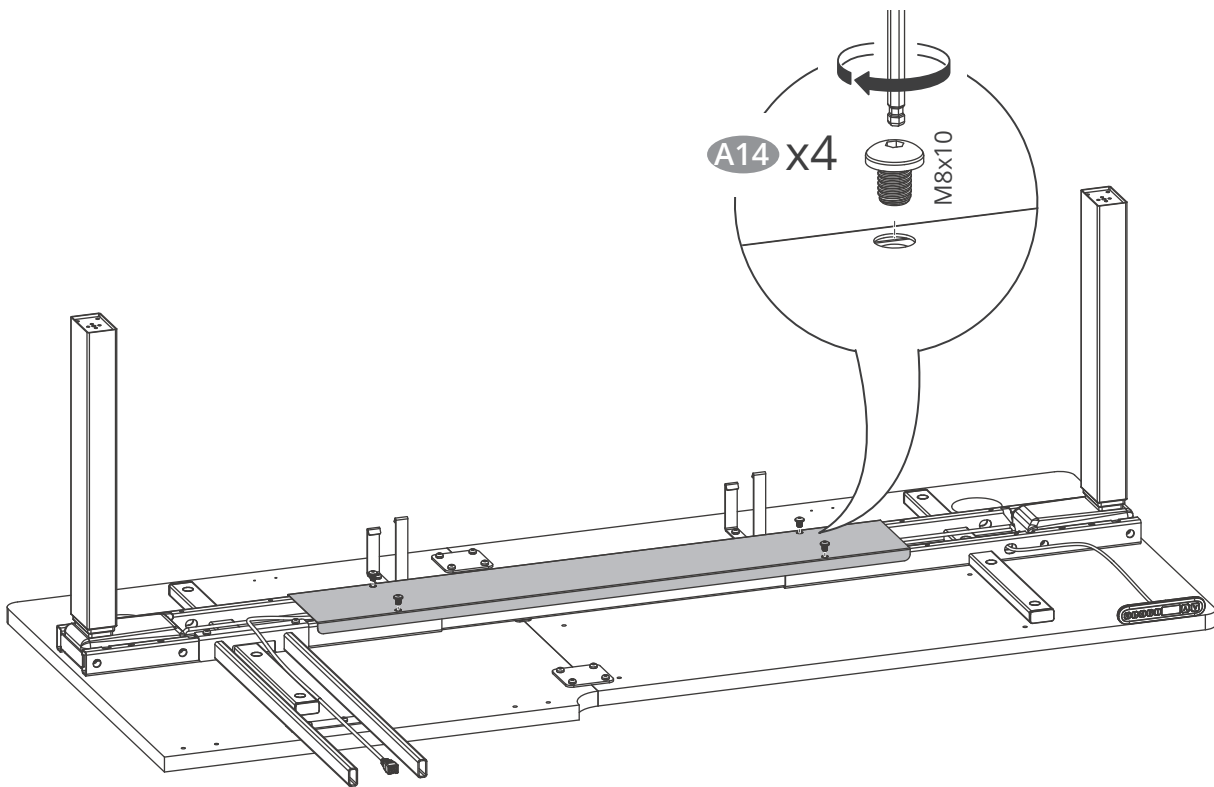

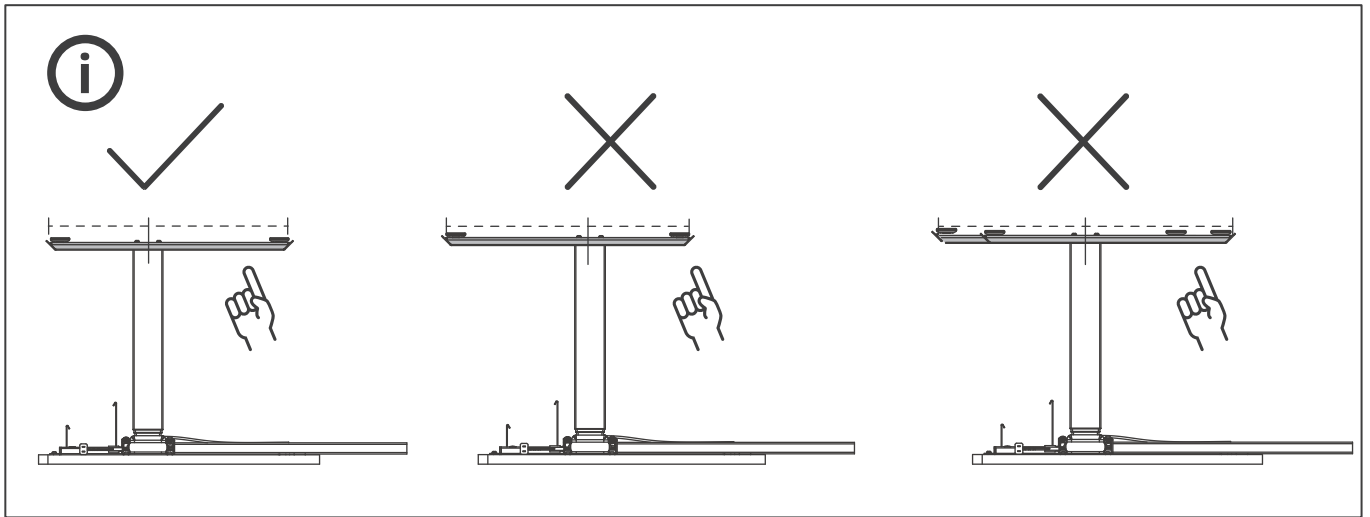

13

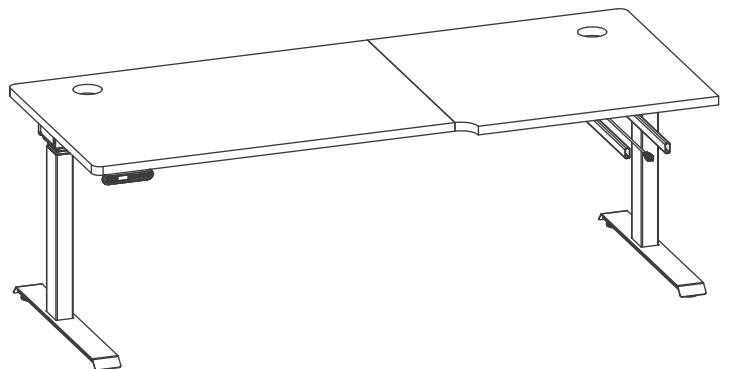
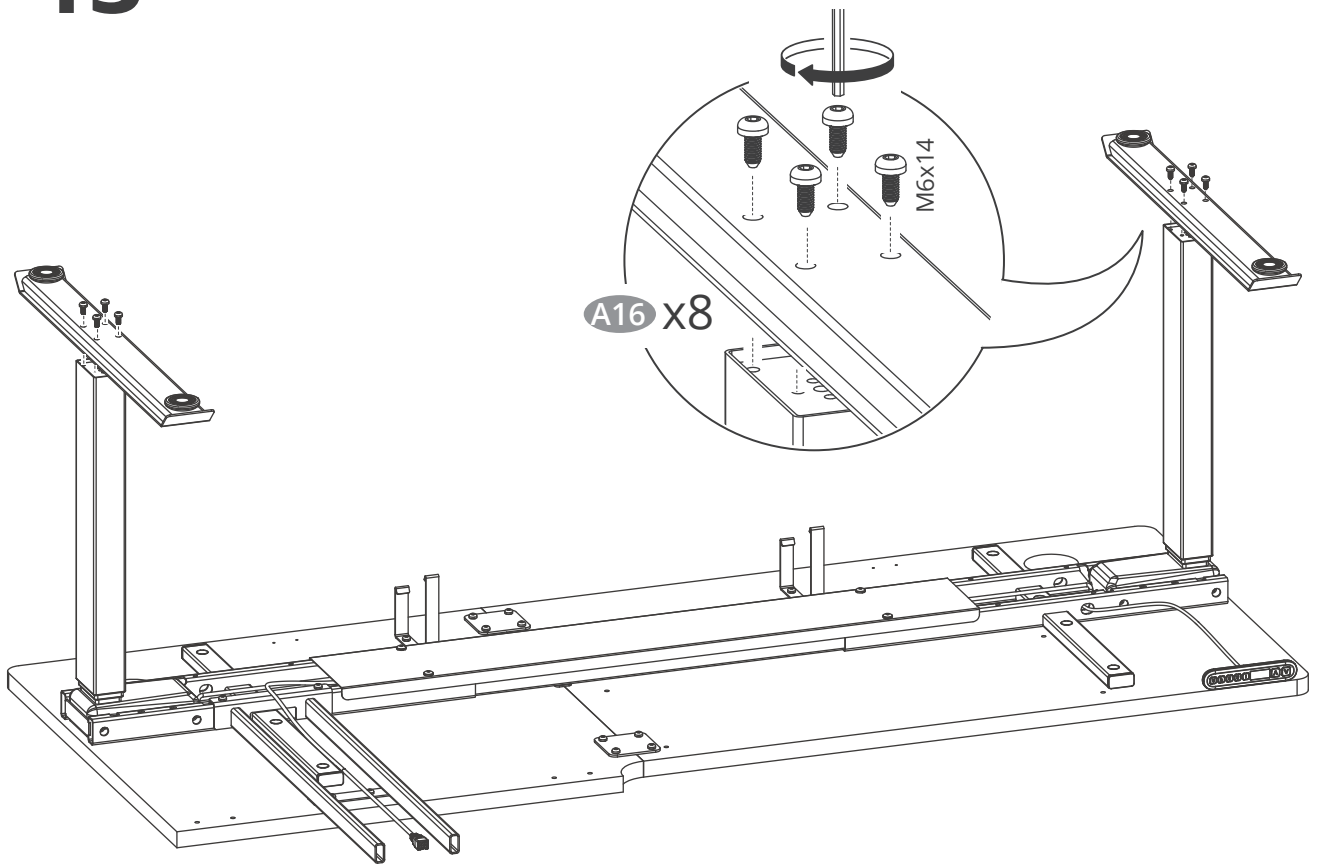

14

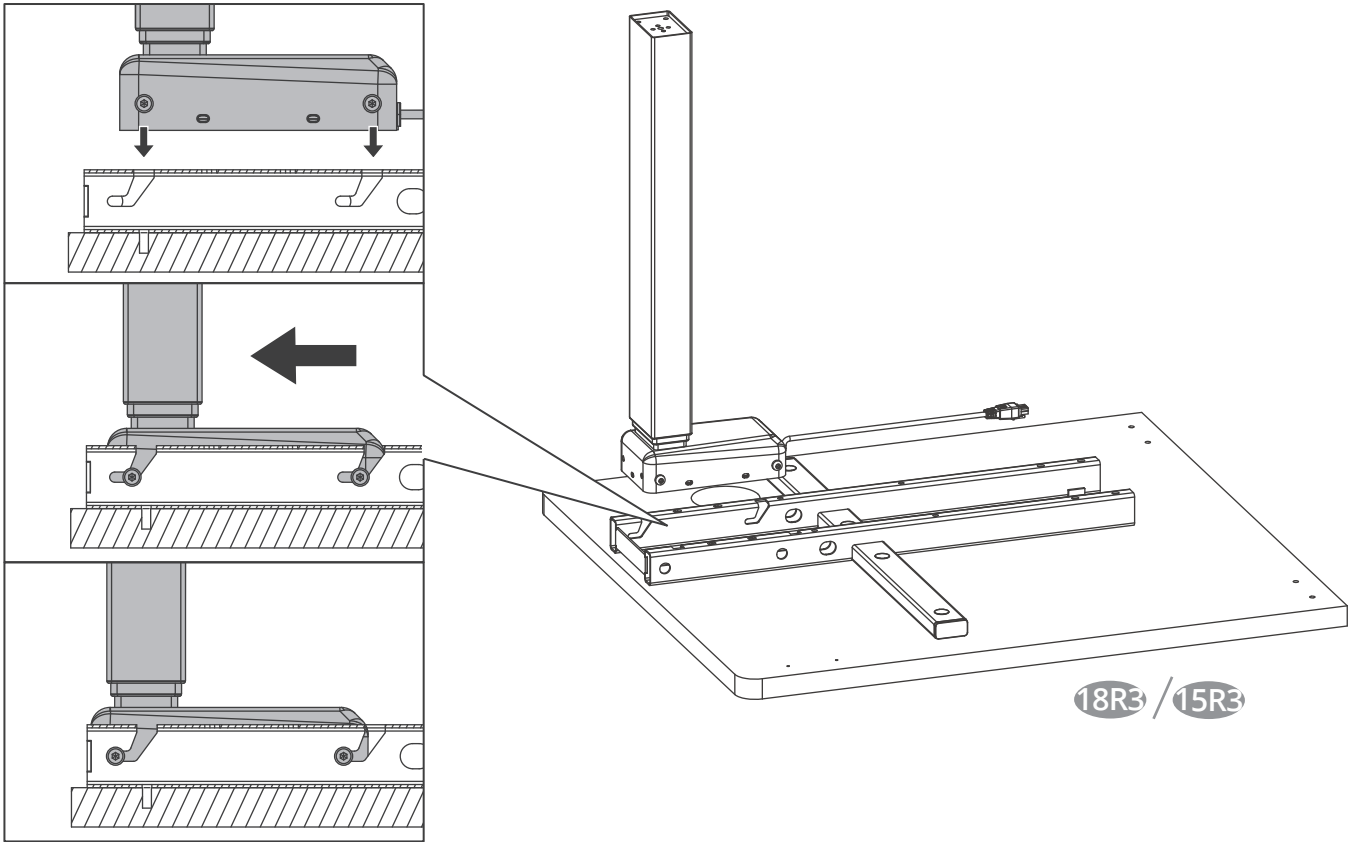

15

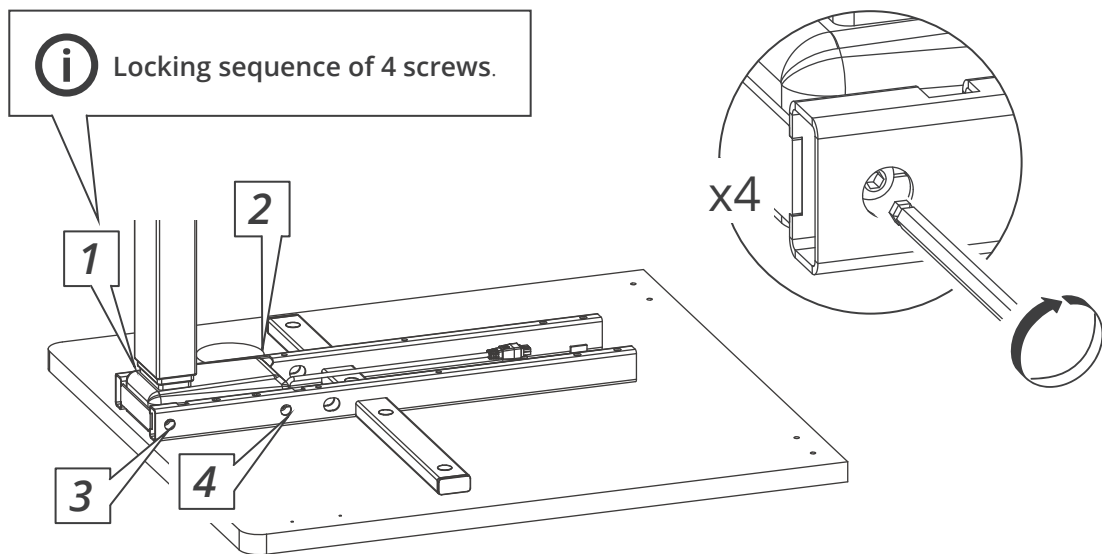

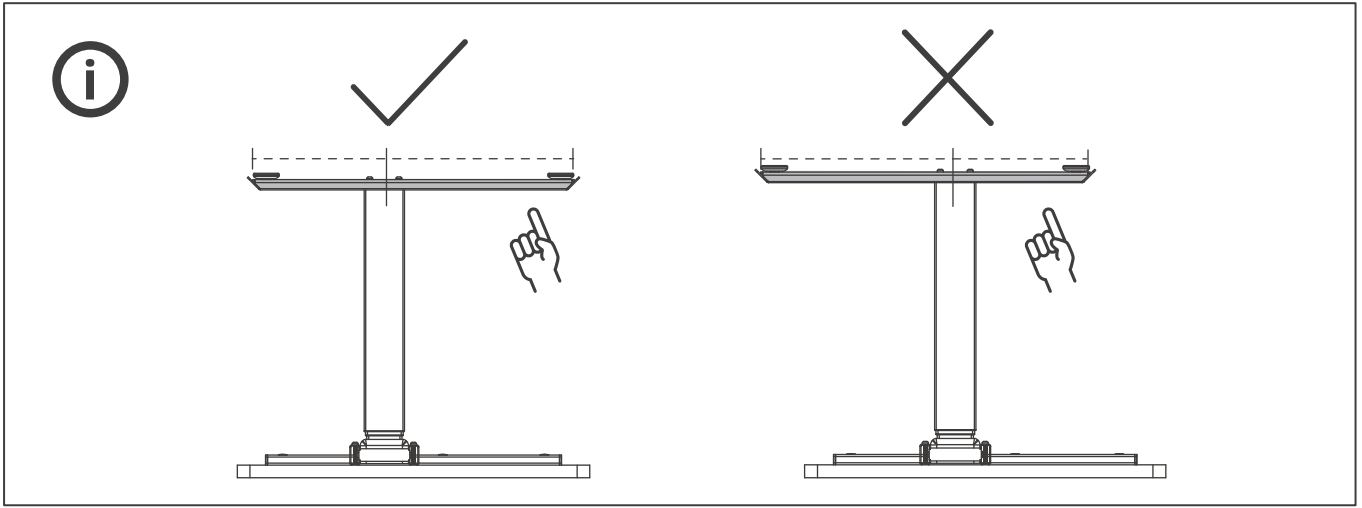

16

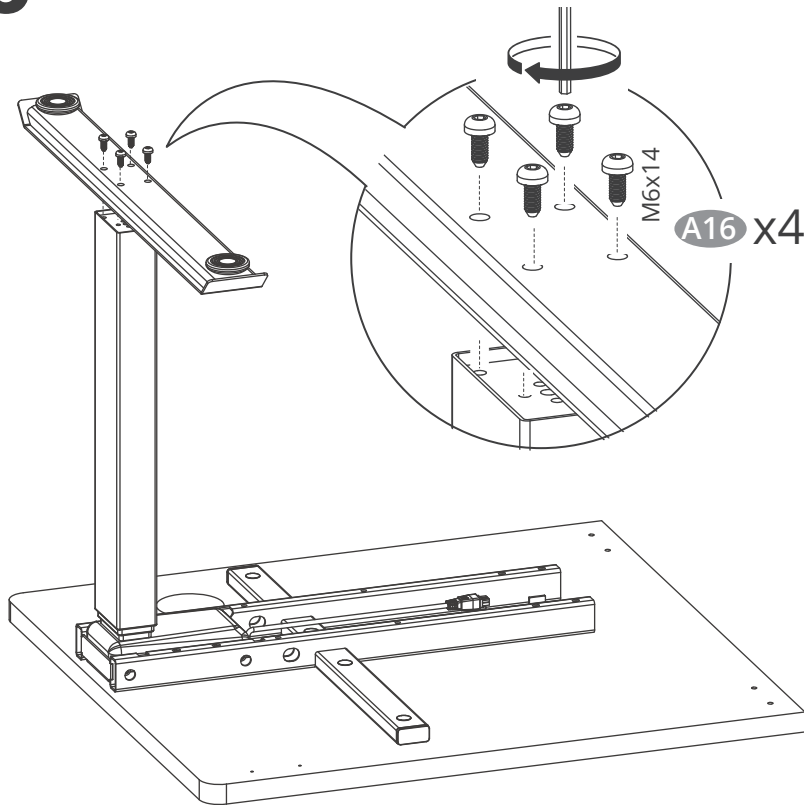

17

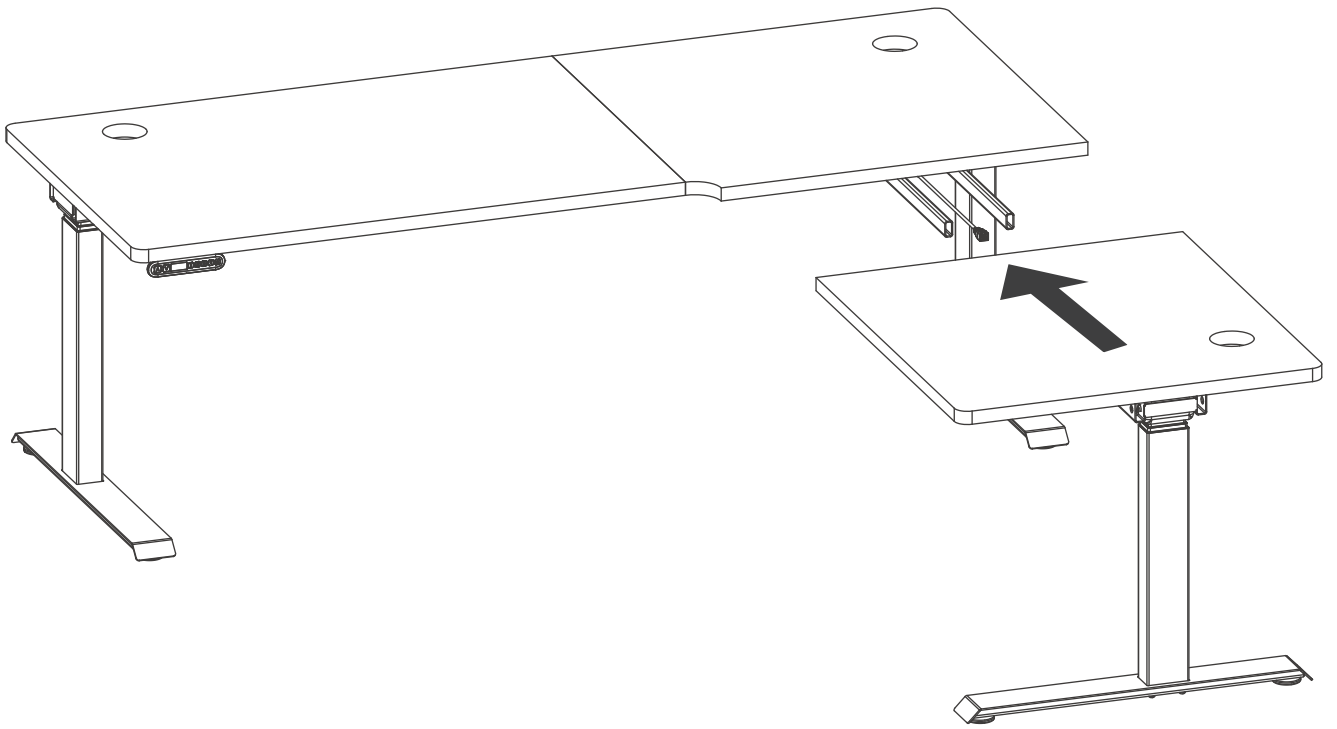

18

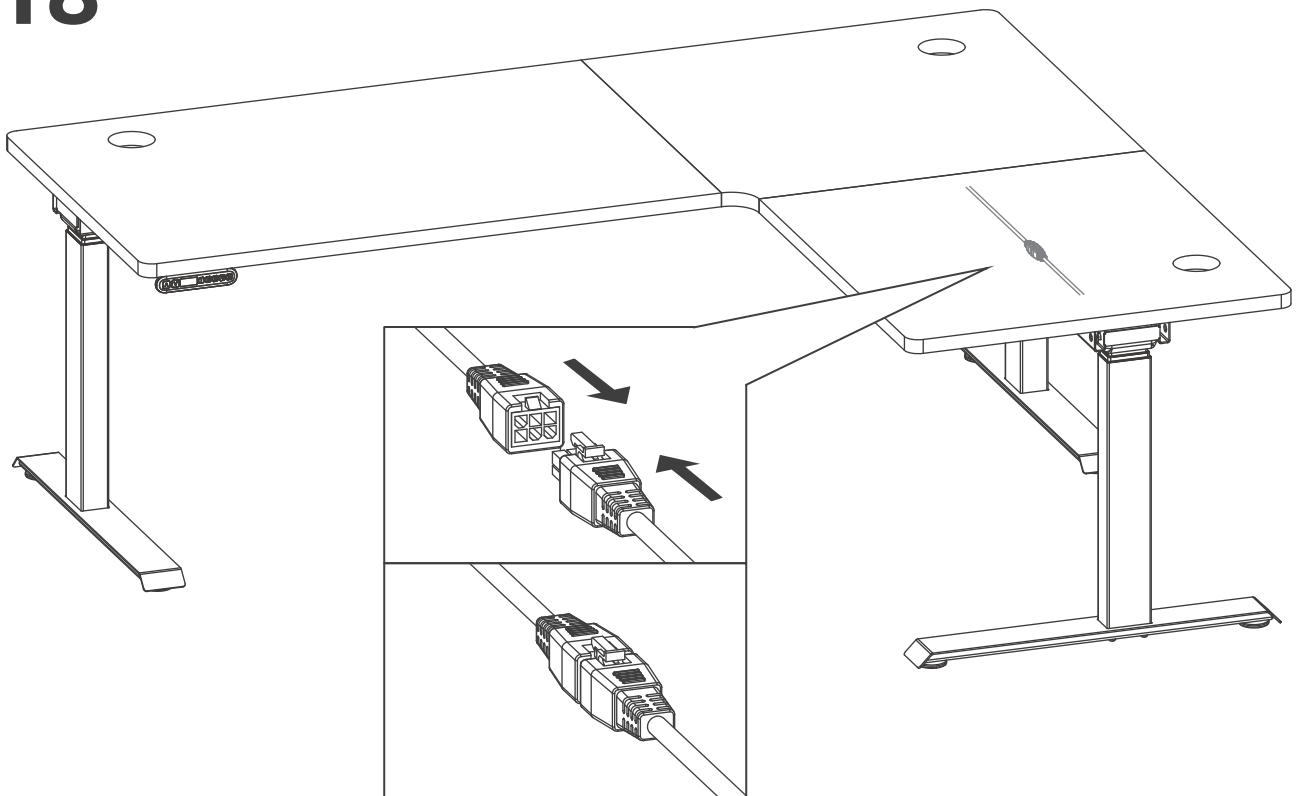

19

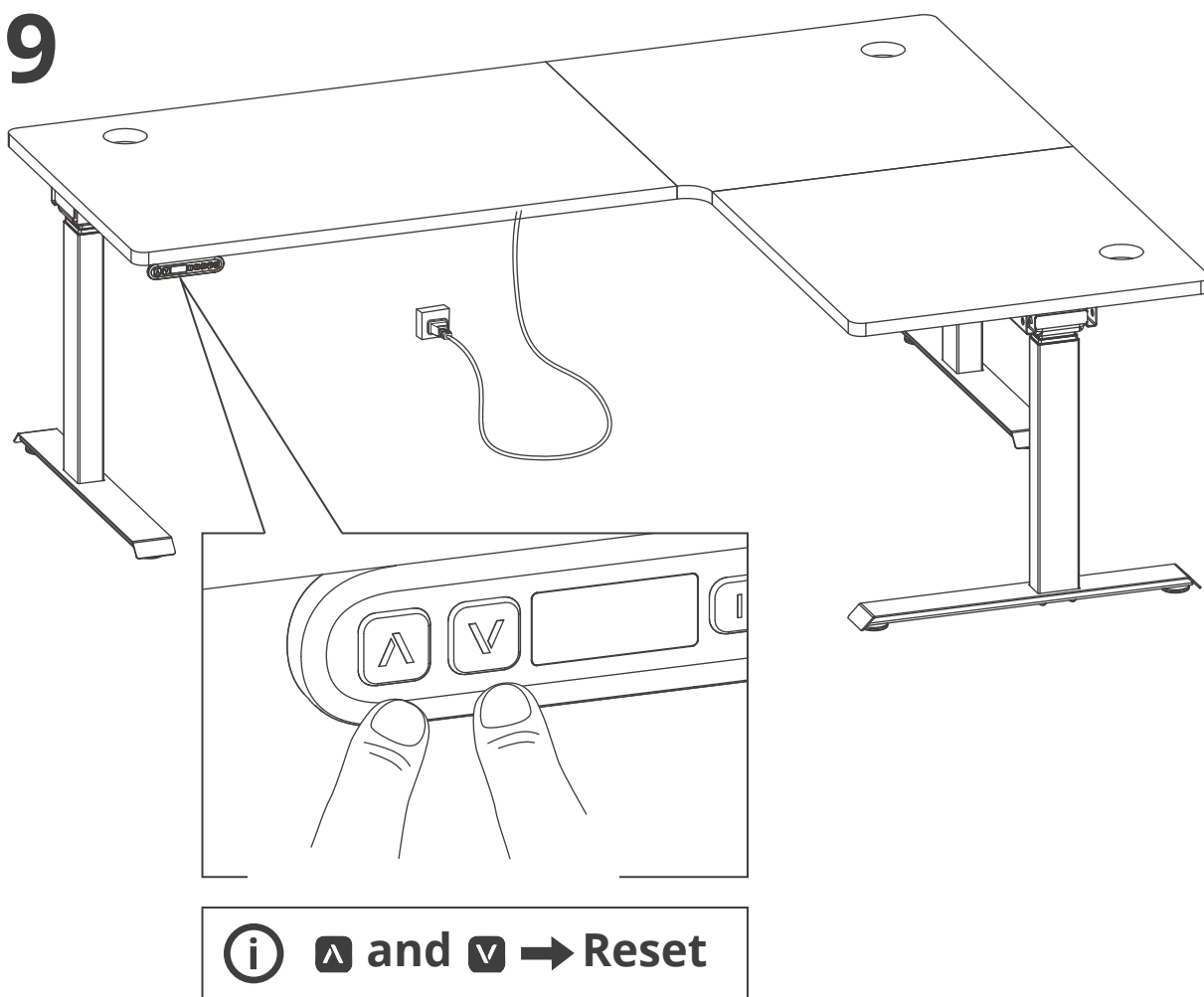

20

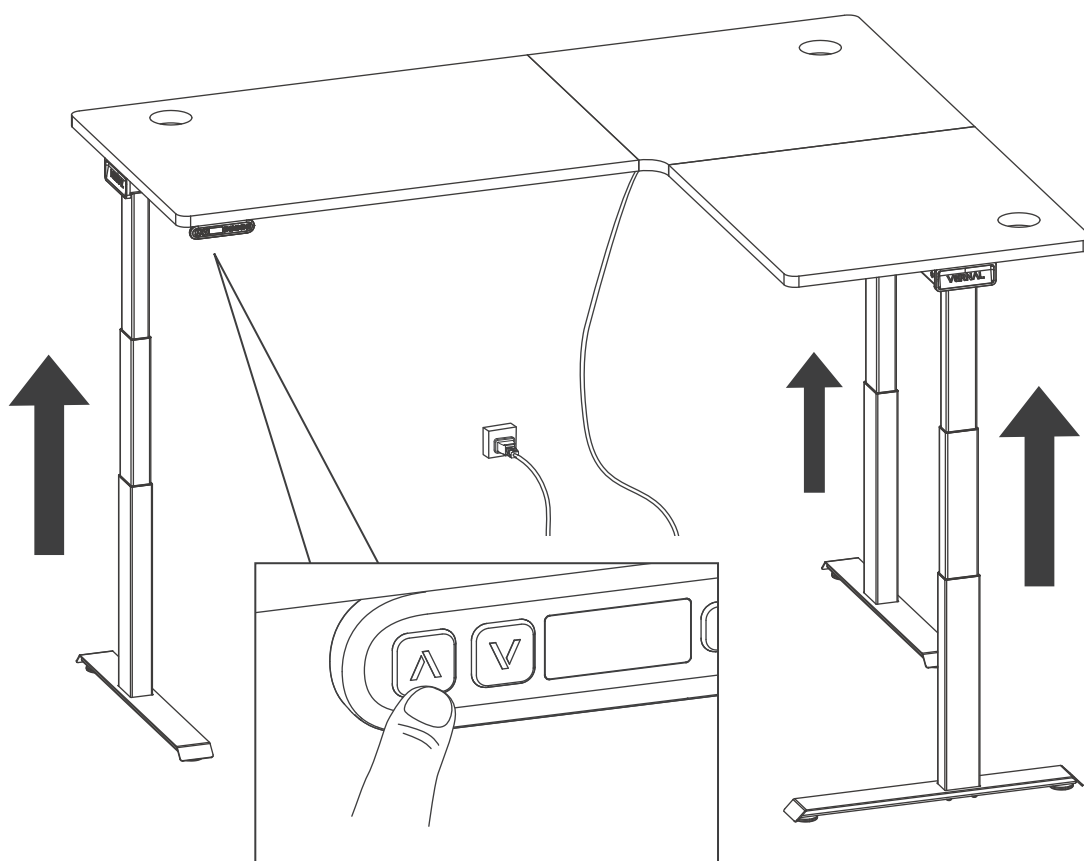

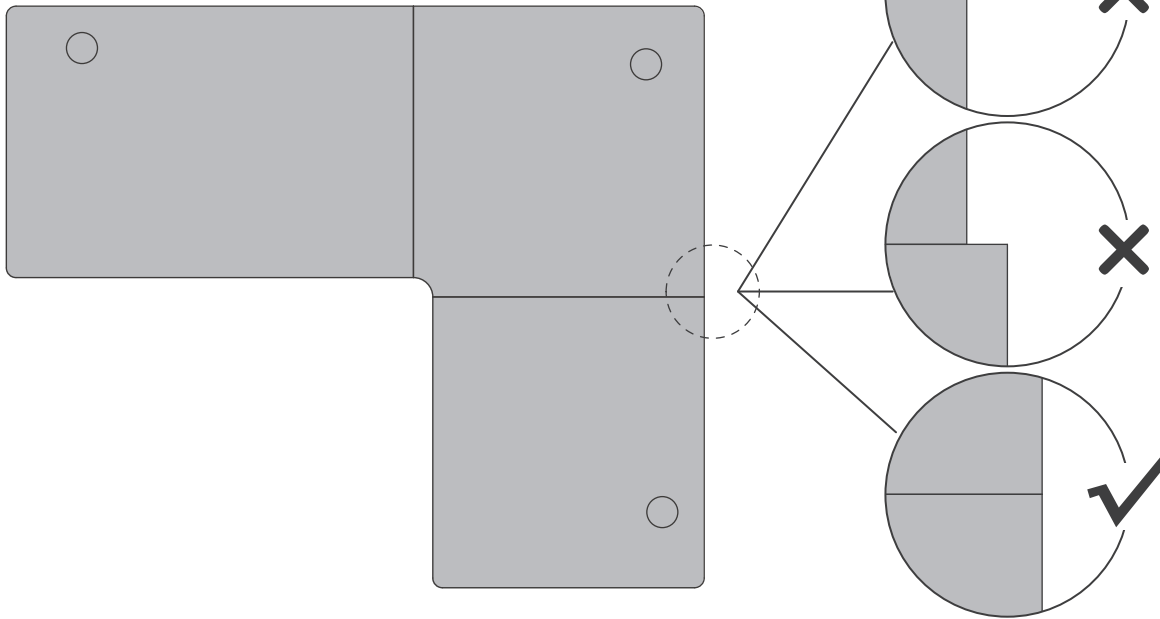

if this side of desktop is not aligned, please follow the step 21 to adjust.

21

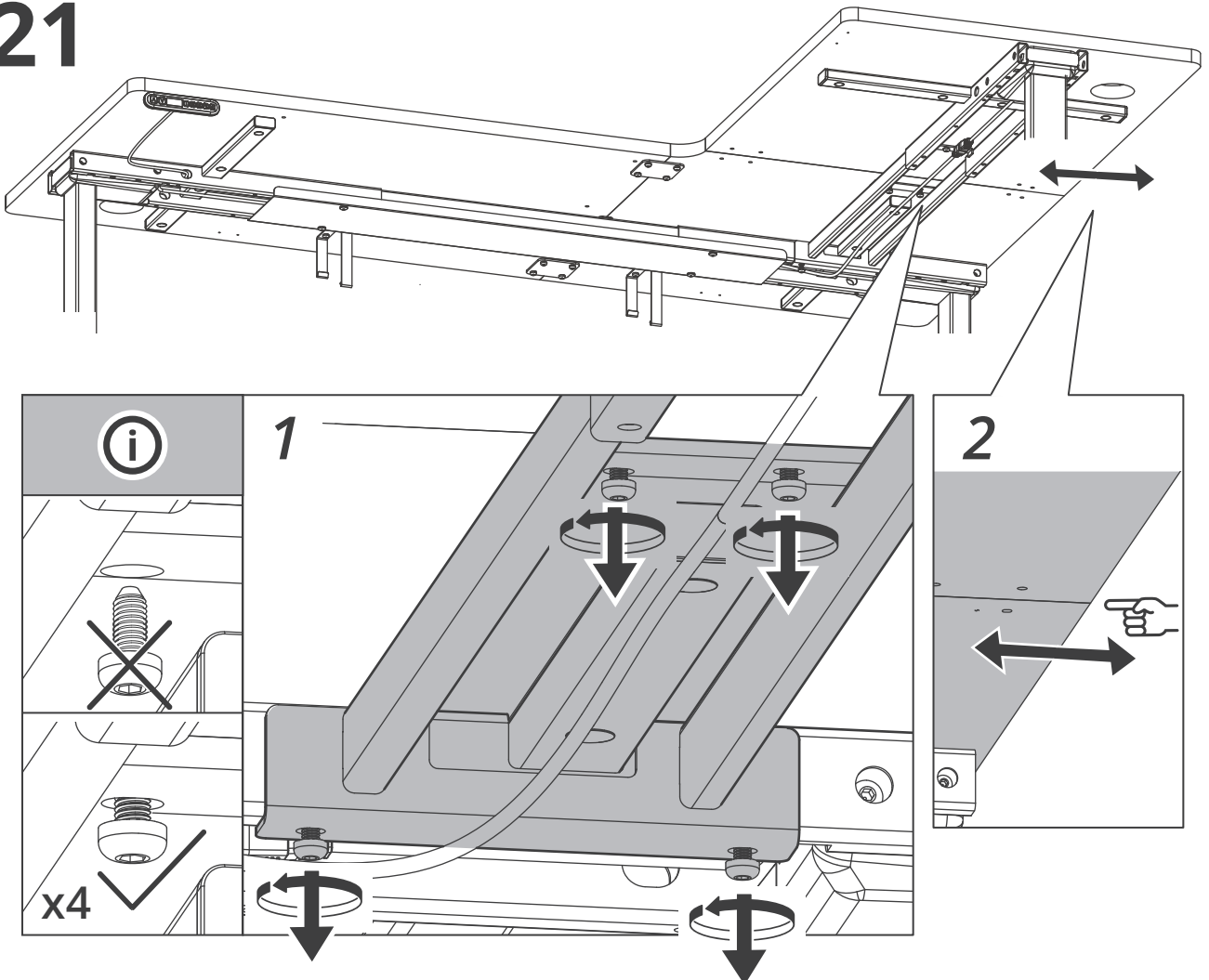

22

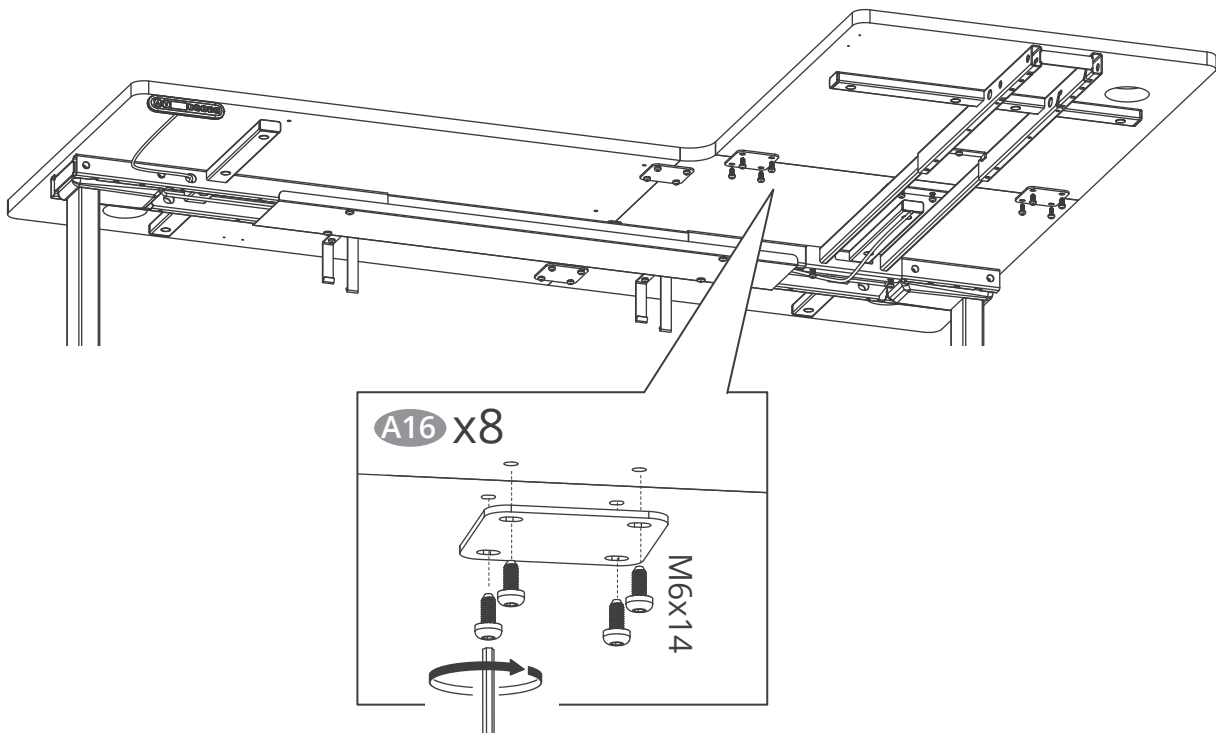

23

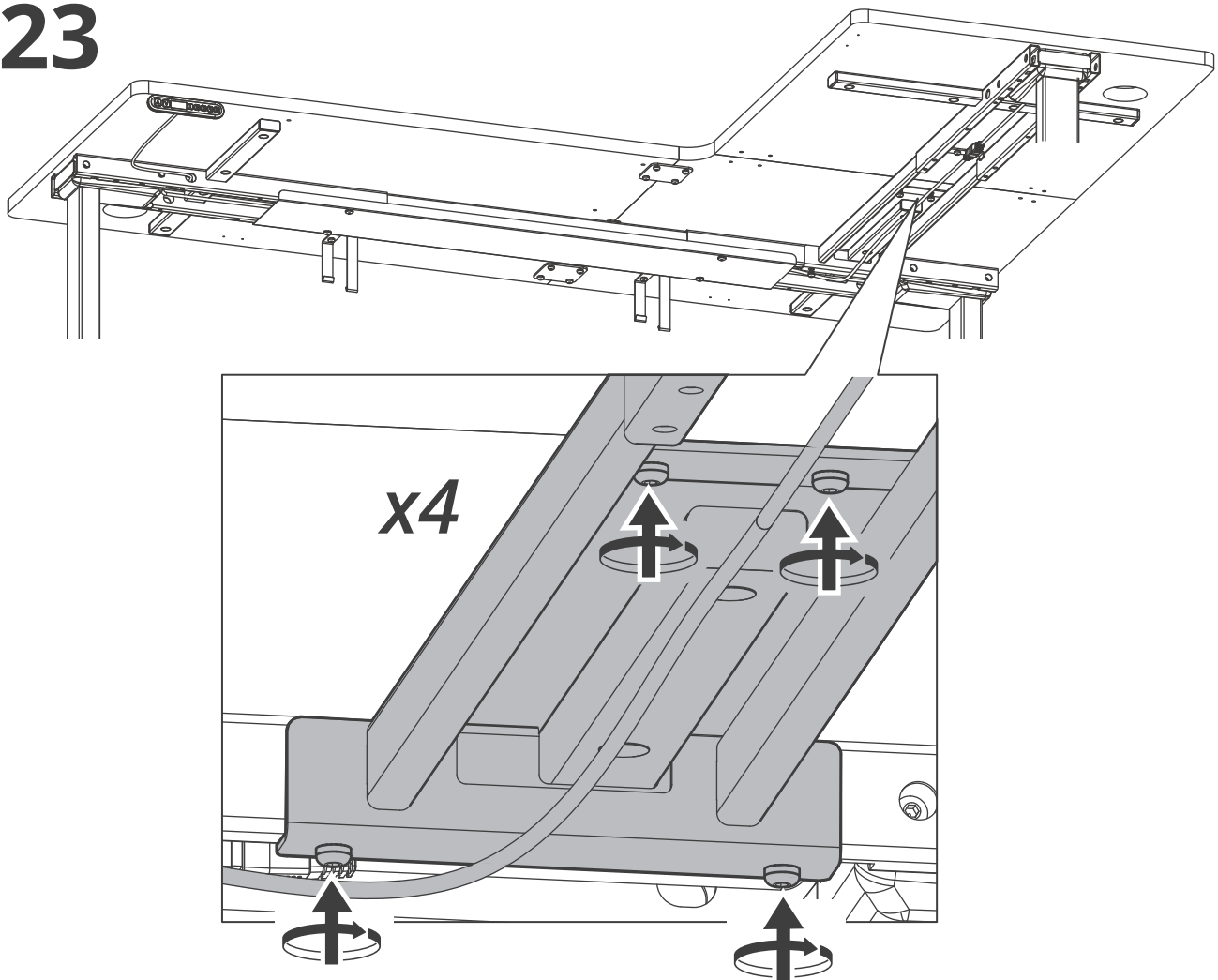

24

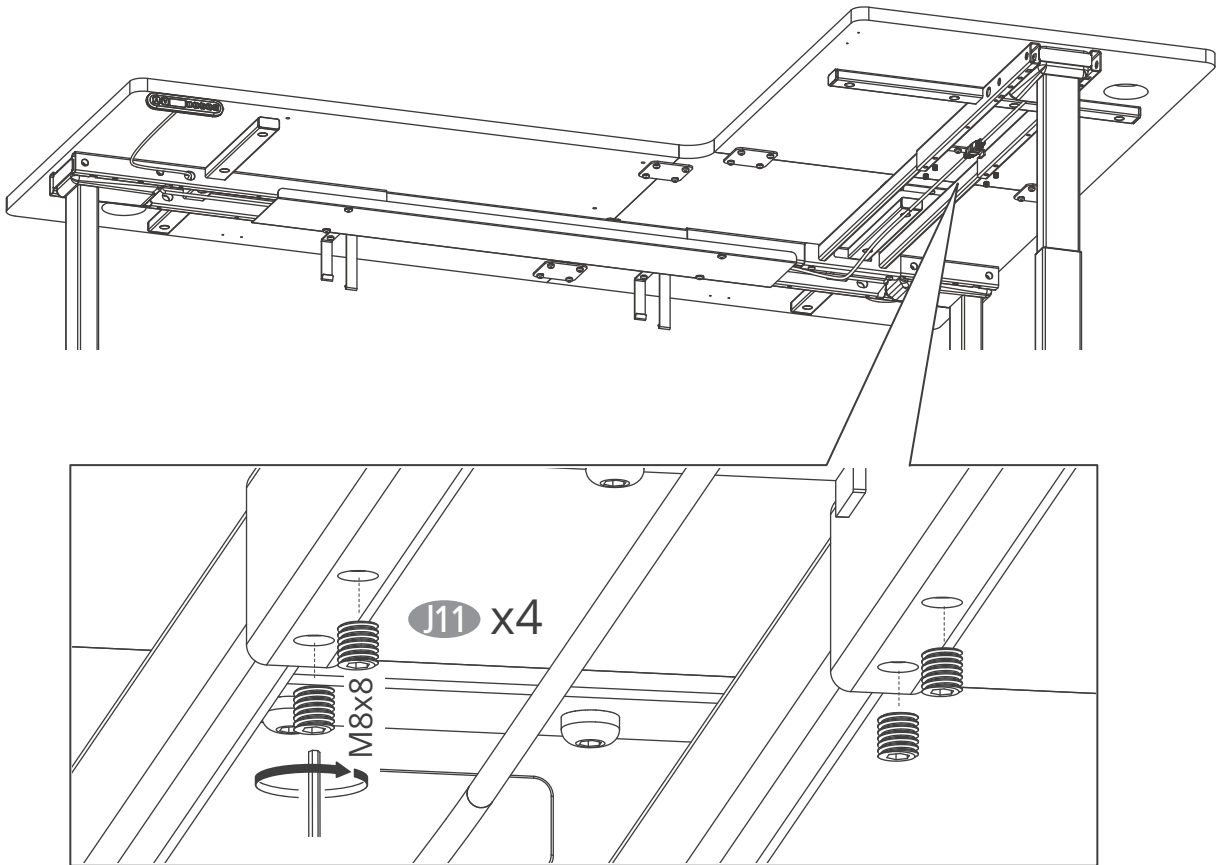

25

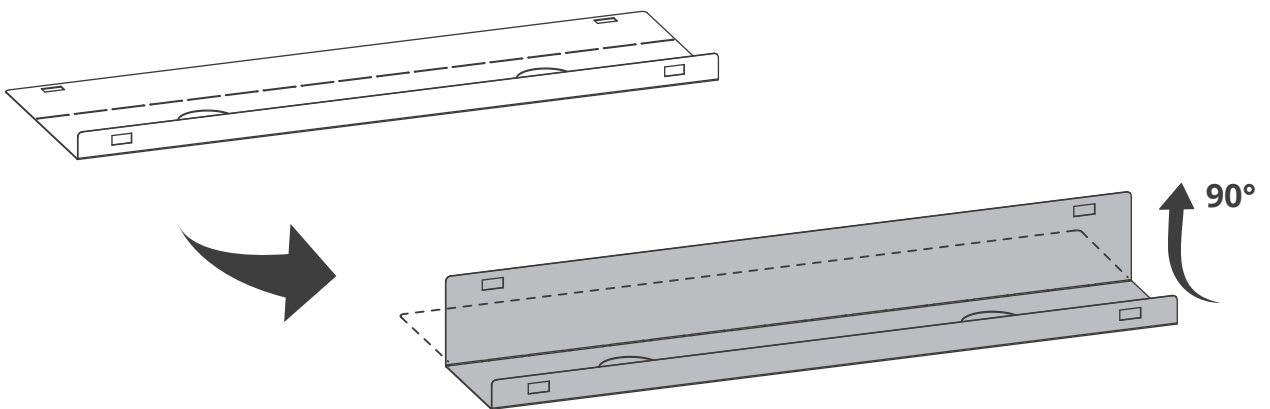

26

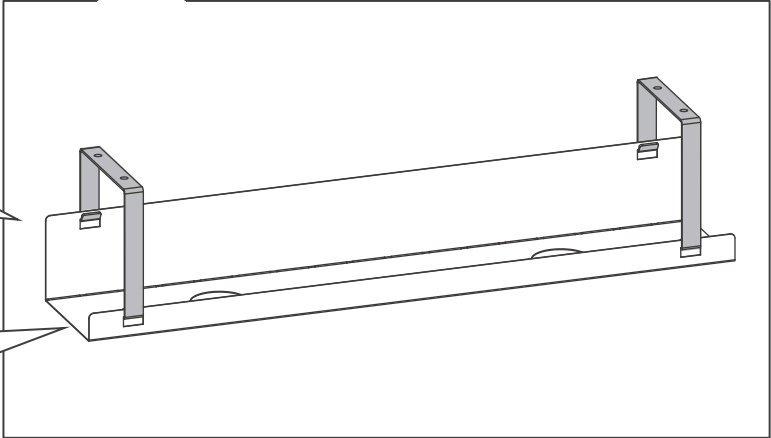
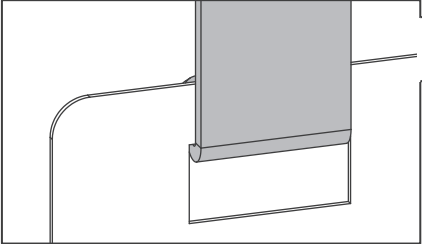
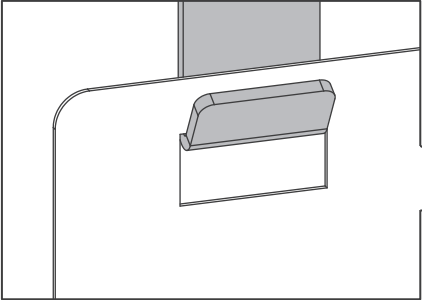
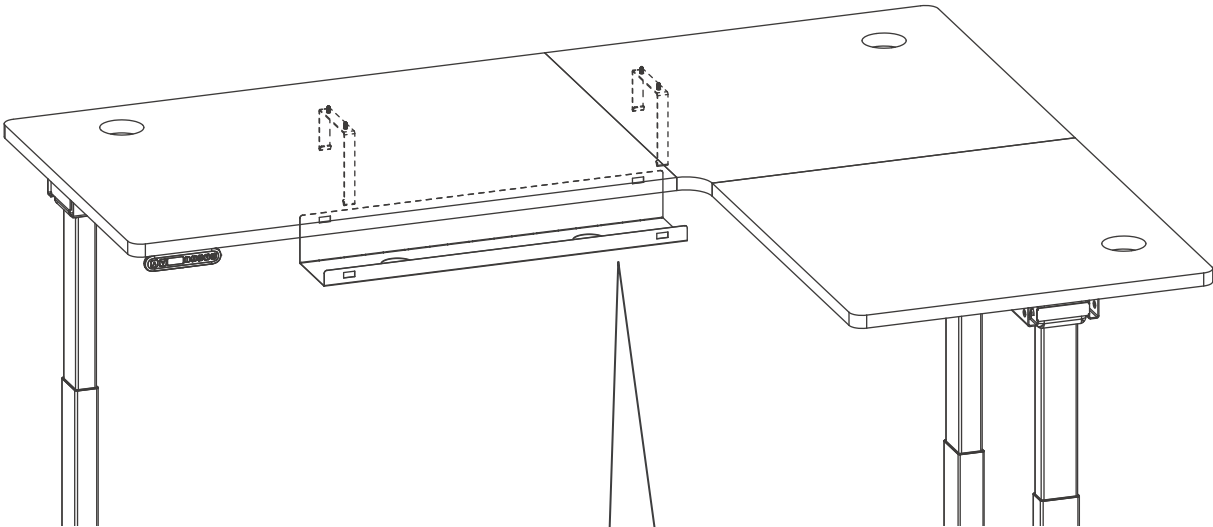

27

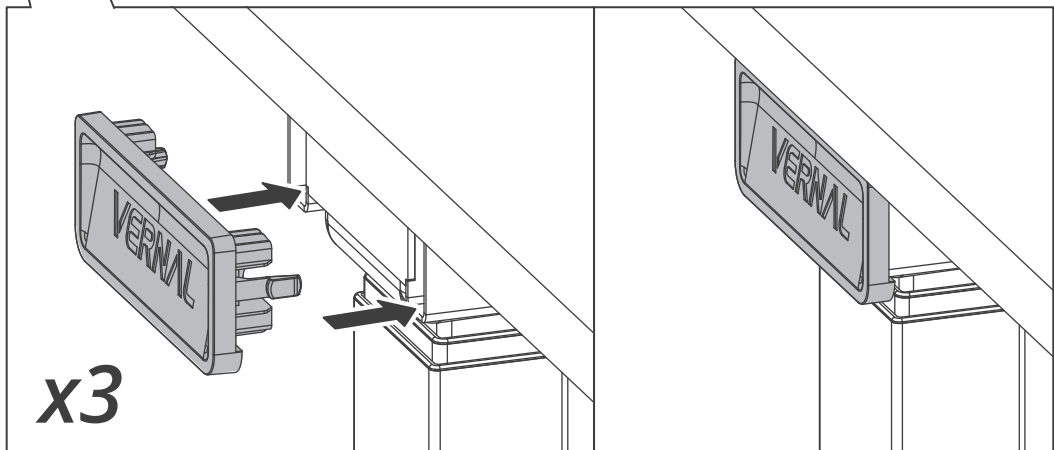
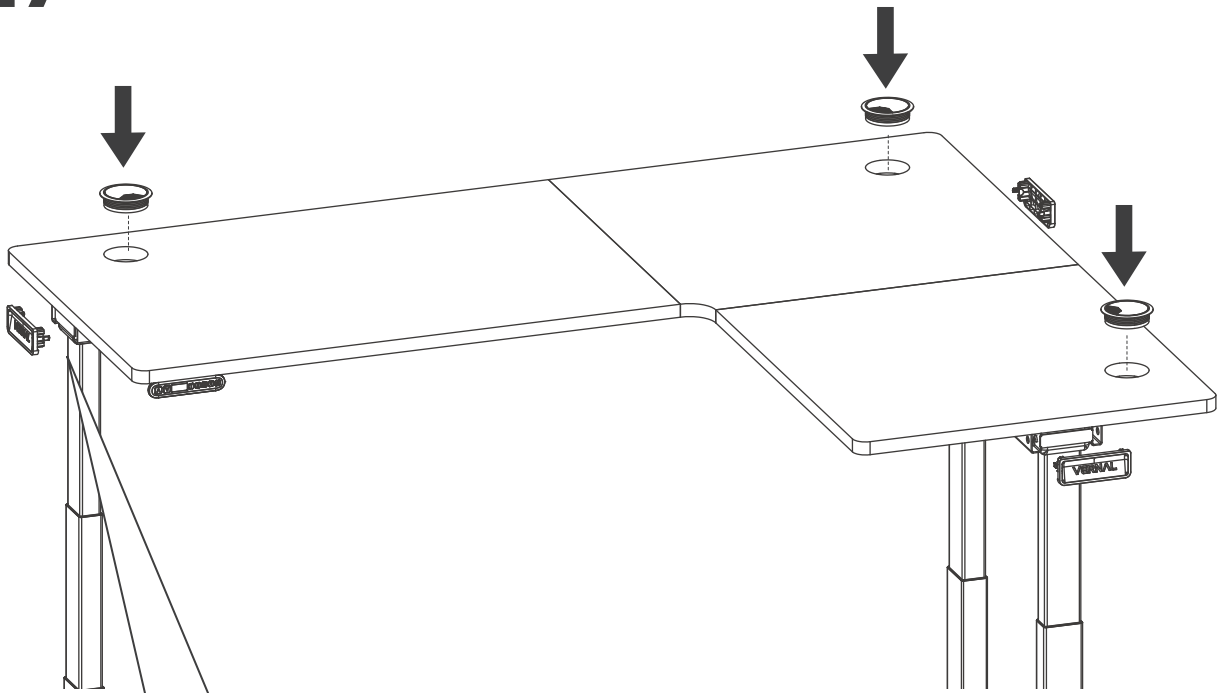

28

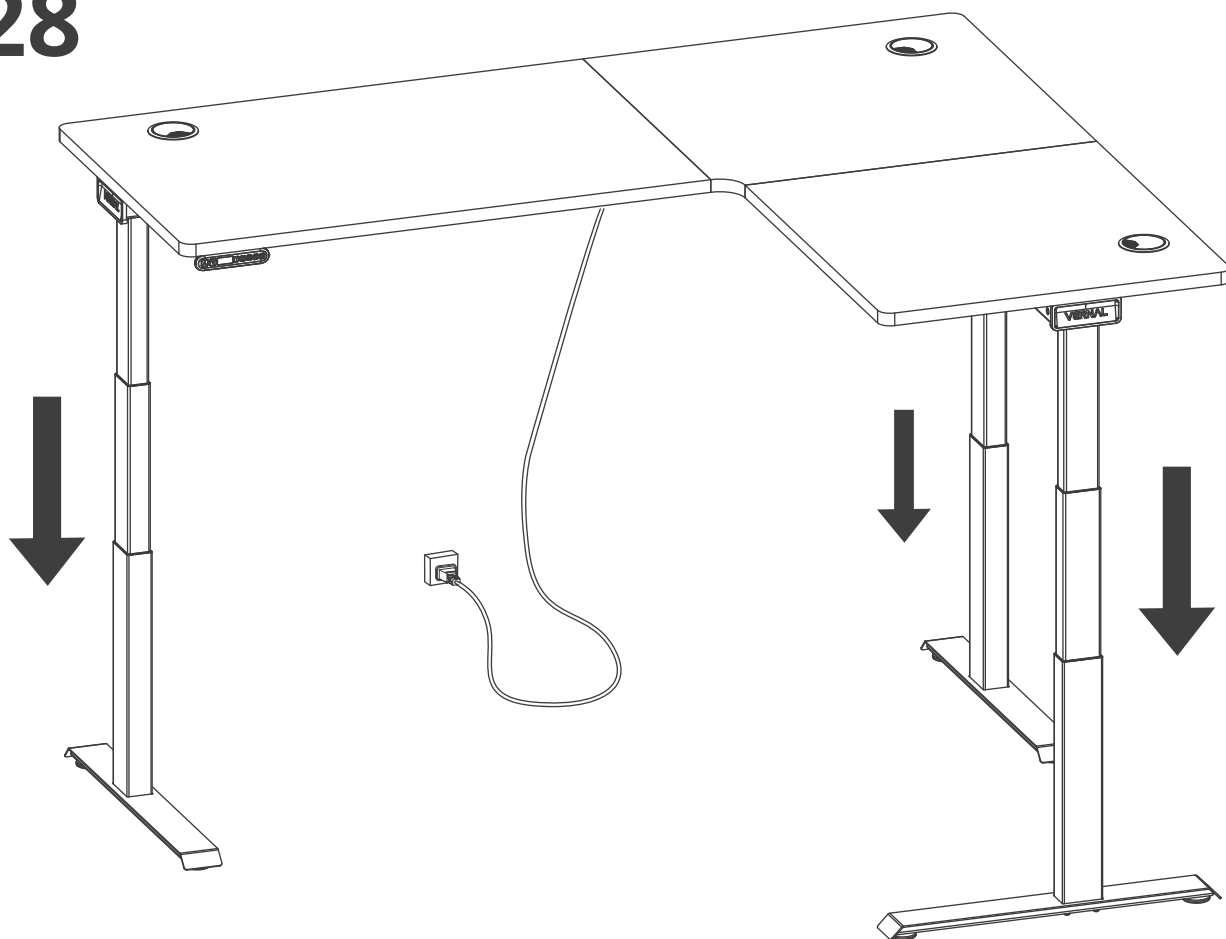

29

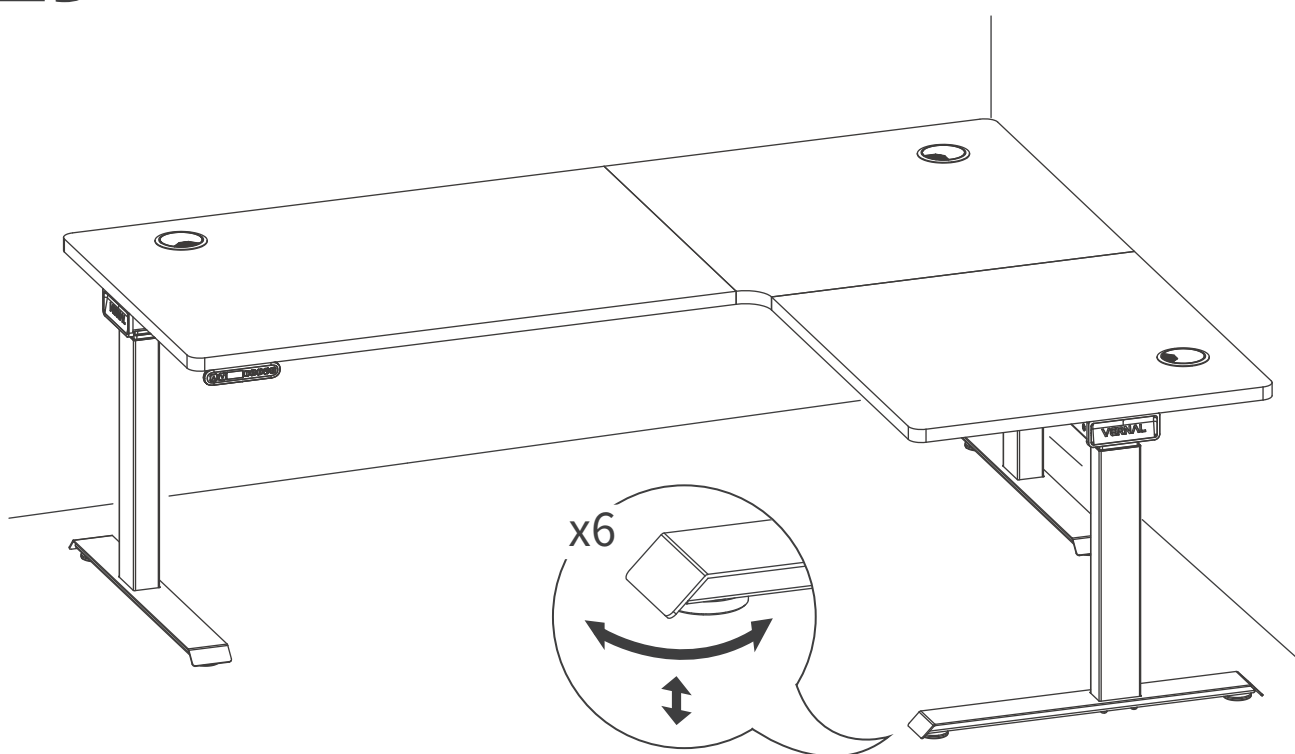



System resetting

Before using the vernal adjustable desk system, please reset the system by pressing and holding the buttons **▲** and **▼** during the whole resetting operation. The motor will be forcibly reset, and the **5E1** or error code will appear on the screen. When the motor reaches its limit, the buzzer will work and the standing desk will rebound for about 5mm. The system will be reset and the screen will display the normal value in inches or centimeters **23.5** / **60.0**.

Button functions

1. Up: press and hold **▲** to enable the motor to rise and release it to stop the motor. The screen will display the current height of the motor and turn off in 10s after this button is released.
2. Down: press and hold **▼** to enable the motor to descend and release it to stop the motor. The screen will display the current height of the motor and turn off in 10s after this button is released.
- 3.1 Setting of memory location 1: Press **▲** and **1** at the same time for 3s. The screen will display the current height in a flashing manner for 3s. The current memory location will be the memory location 1.
- 3.2 Memory 1 Operation: Short pressing is the default mode. See Section Limit setting point 3 for details about long pressing and short pressing.
 - (1) In the short pressing mode, if the motor is not at any location of the memory 1, press **1** and release it. The motor will run to the location of the memory 1, and its height will be displayed in real time.
 - (2) In the long pressing mode, if the motor is not at any location of the memory 1, long-press **1**. The motor will run to the location of the memory 1, and the screen will display the location value of the memory 1.

4.1 Setting of memory location 2: see 3.1



4.2 Memory 2 Operation: see 3.2

5.1 Setting of memory location 3: see 3.1



5.2 Memory 3 Operation: see 3.2



6.1 Setting of memory location 4: see 3.1



6.2 Memory 4 Operation: see 3.2



7. Lock: press and hold  for 5s. The screen will display LOC in a flashing state for 3s, and buttons will be locked. No matter which button is operated, the motor will not work. The screen will turn off in 3s. In this case, press any button. The screen will light up, displaying LOC for 3s, and then turn off, which will be repeated without unlocking buttons. Then press and hold  for 5s. The screen will display the current height, buttons will be unlocked, and the motor will work again.



Limit setting



1.1 Upper Limit Setting: press and hold  and  at the same time for 3s. The current location will be set to the upper limit, and the screen will display HLS in a flashing state for 3s, and then remain in the HLS interface. In this case, press any button to exit the limit display interface.

1.2 Low Limit Setting: press and hold  and  at the same time for 3s. The current location will be set to the lower limit, and the screen will display LLS in a flashing state for 3s, and then remain in the LLS interface. In this case, press any button to exit the limit display interface.





1.3 Limit Clear: press and hold ,  and  at the same time for 3s. The custom limits will be cleared, and the screen will display LS- in a flashing state for 3s, and then remain in the LS- interface. In this case, press any button to exit the limit display interface.

1.4 Change of the unit of height: change between centimeter and inch. Press and hold  and  for 3s to enable the change between centimeter and inch. A21 represents “centimeter” while A22 represents “inch”. The unit will flash for 3s and then remain on the screen. Press any button to exit this interface.

2. Anti-collision & anti-pinch sensitivity adjustment: press and hold  and  for 3s to increase the anti-collision sensitivity by a level between A01 and A03. The screen will display the anti-collision sensitivity corresponding to A01-A03. Repeat the above operation for adjust it again. The anti-collision sensitivity decreases from A01 to A03. A01 represents the highest sensitivity while A03 represents the lowest sensitivity. (The default setting is A02, i.e. the middle sensitivity.)

3. Change between long pressing and short pressing for memory location recall: press and hold  and  for 3s, to change the long press and short pressing modes. A11 represents long pressing, while A12 represents short pressing. The mode will flash for 3s and remain on the screen. Press any button to exit this interface.

Height value adjustment

1. Run the motor to the lowest location, and press and hold  for 10s. The LED indicator will flash. Press  or  to adjust the value, and then press and hold  for 5s to save this value.

Error codes

ES1: The height difference between right leg and left leg exceeds the set value.
Troubleshooting: Reset forcibly to erase the error code.

HOT: Continuous operation for 4min.
Troubleshooting: Take a 20min break.

EE0: Power failure in operation.
Troubleshooting: Power on this product again and conduct the resetting.

ELA: The ports for lifting legs on the control box are disconnected.
Troubleshooting: reconnect the lines of lifting legs and conduct the resetting operation forcibly.

E2A: Overloading.
Troubleshooting: remove the loading and make the loading evenly distributed. And conduct the resetting operation forcibly.

If any other error code appears, please contact us for troubleshooting.
service@vernalspace.com



Note :

In case of any obstacles after the anti-pinch and anti-collision function is enabled, the system will run reversely for 20-40min.



FR

Cet appareil se recycle

REPRISE
À LA LIVRAISON



À DÉPOSER
EN MAGASIN



À DÉPOSER
EN DÉCHÈTERIE



Points de collecte sur www.quefairedemesdechets.fr
Privilégiez la réparation ou le don de votre appareil !